

SERVICE MANUAL

© 2002-3 PRINTED IN JAPAN
B51-7931-00 (S) 3397

- This service manual does not include information on the CD mechanism assembly (exploded view, parts list, schematic diagram or mechanism operation description).
For such information, please refer to the CD mechanism assembly service manual (X92-4450-0x: B51-7889-00) for Z738.
For such information, please refer to the CD mechanism assembly service manual (X92-4590-0x: B51-7933-00) for KDC-X959/Z939, Z838W.

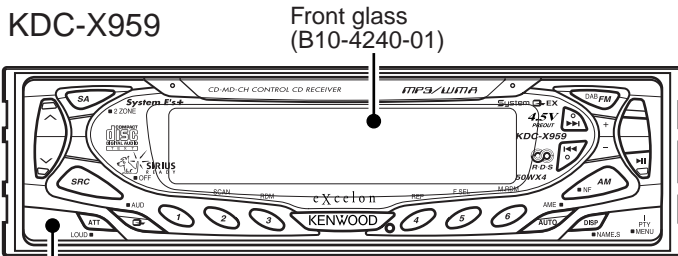

Panel Assy
(A64-2687-11)

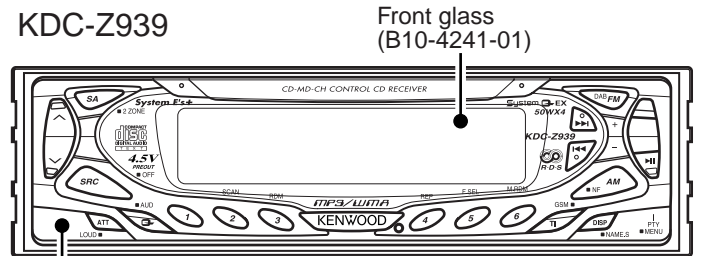

Panel Assy
(A64-2688-11)

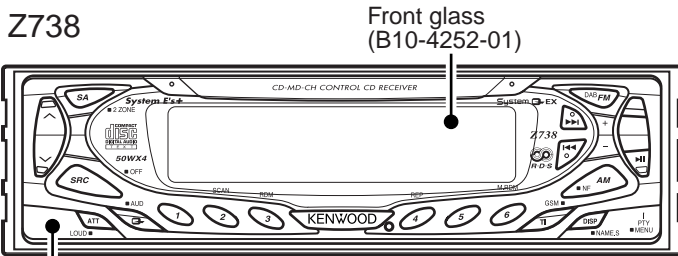

Panel Assy
(A64-2723-11)

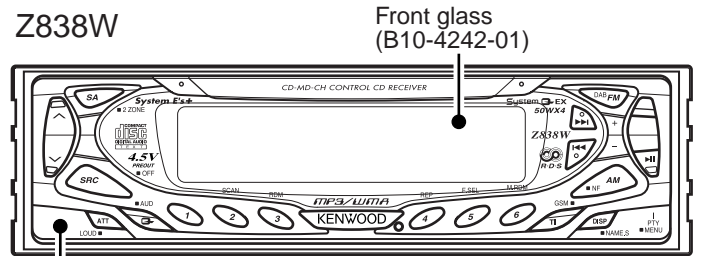

Panel Assy
(A64-2689-11)

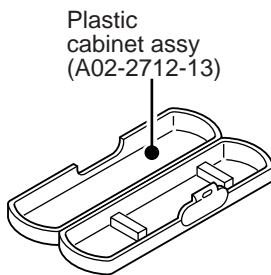

Plastic cabinet Assy
(A02-2712-13)

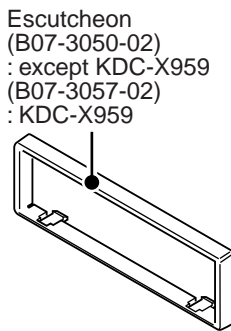

Escutcheon
(B07-3050-02)
: except KDC-X959
(B07-3057-02)
: KDC-X959

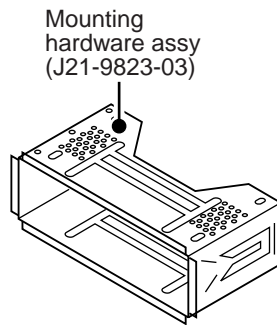

Mounting hardware Assy
(J21-9823-03)

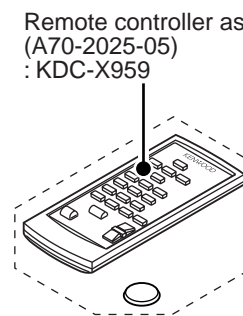

Remote controller Assy
(A70-2025-05)
: KDC-X959

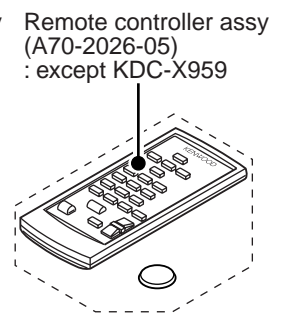

Remote controller Assy
(A70-2026-05)
: except KDC-X959

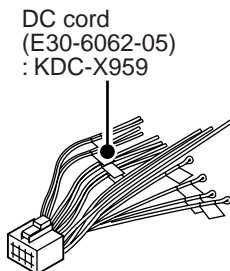

DC cord
(E30-6062-05)
: KDC-X959

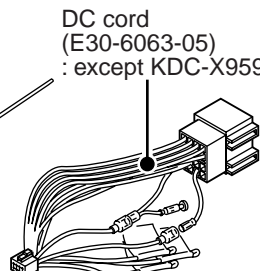

DC cord
(E30-6063-05)
: except KDC-X959

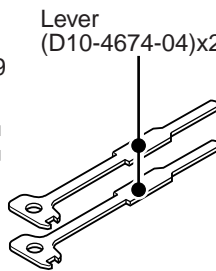

Lever
(D10-4674-04)x2

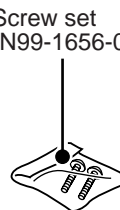

Screw set
(N99-1656-05)

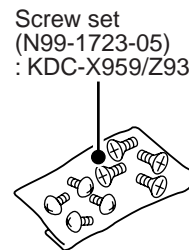

Screw set
(N99-1723-05)
: KDC-X959/Z939



Antenna adaptor
(T90-0523/0534/0552-05)
: except KDC-X959



KDC-X959/Z939, Z738, Z838W

BLOCK DIAGRAM

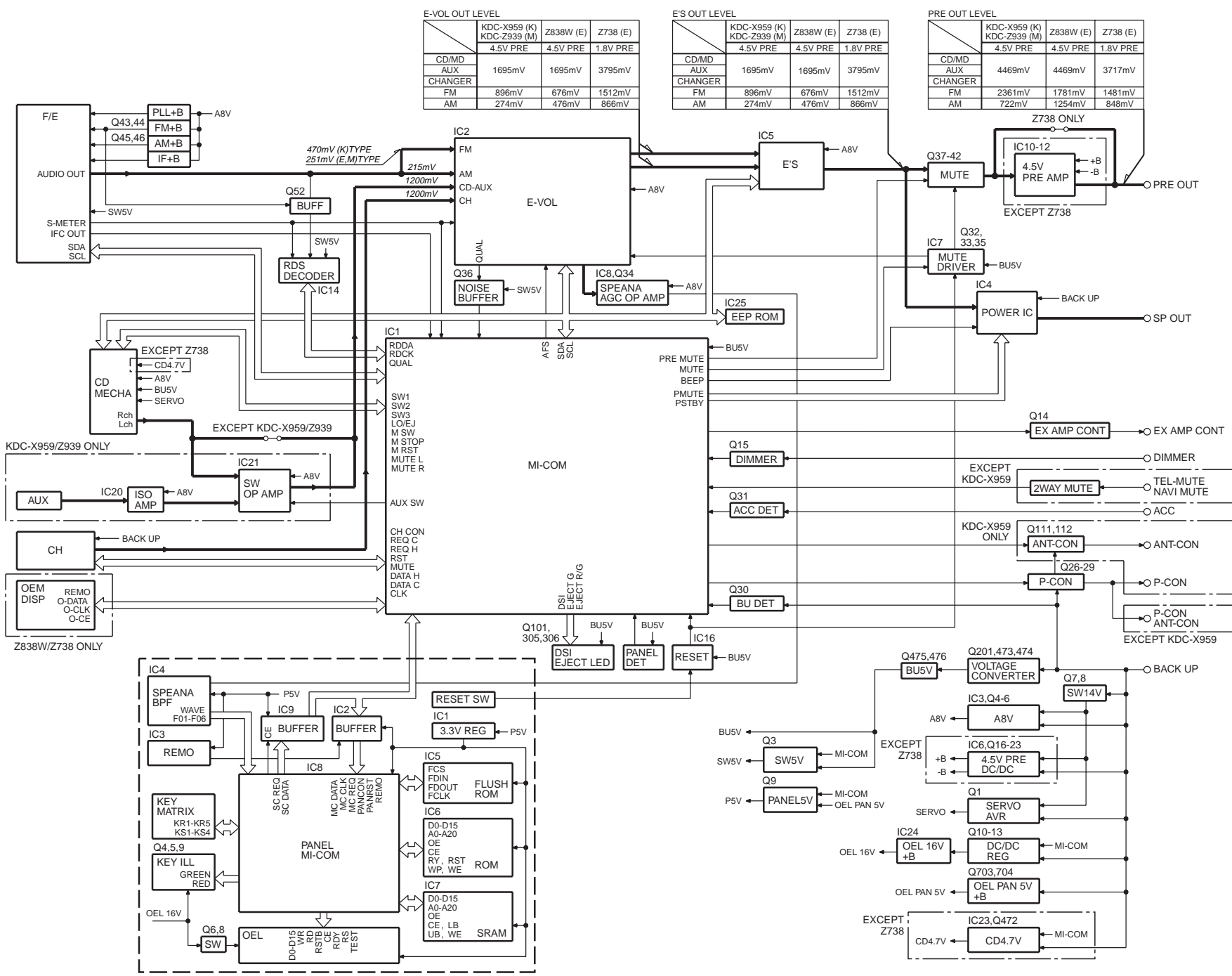

COMPONENT DESCRIPTION

● SWITCH UNIT (X16-169X-XX)

Ref.No.	Component Name	Application/Function	Operation/Condition/Compatibility
IC1	SI-3033LSA-TL	3.3V AVR	+3.3V Output
IC2	TC74HC4050AFT	Buffer	5V → 3.3V logic level shifting
IC3	RS-171	Remote sensor IC	
IC4	BA3830F	BPF IC	BPF for the spectrum analyser indicator
IC5	M25P20	Flush ROM	For custom display data of the indicator
IC6	MX23L3213T1109	ROM	For display data of the indicator
IC7	IS61LV641615TI	SRAM	For display data of the indicator
IC8	703107AGJ121	Panel MI-COM.	
IC9	TC7WT126FU	Buffer	3V → 5V logic level shifting
IC10	TC7SH08F	WE/WR control signal generation	AND gate
Q4	DTC123JUA	Key illumination Red SW	When a base goes Lo, Q4 is turned on, and key illumination Red is lit.
Q5	DTC123JUA	Key illumination Green SW	When a base goes Lo, Q5 is turned on, and key illumination Green is lit.
Q6	CPH3105	OEL+B SW	When Q8's base goes Hi, Q6 is turned on, and OEL 16V power line is supplied to OEL module.
Q8	DTC114EUA or UN5111		
Q9	DTC123JUA	Key illumination Blue SW	When a base goes Lo, Q9 is turned on, and key illumination Blue is lit.

● ELECTRIC UNIT (X25-927X-XX)

Ref.No.	Component Name	Application/Function	Operation/Condition/Compatibility
IC1	UPD703033GFA14	System MI-COM.	For KDC-X959/Z939, Z838W
IC1	UPD703033GFA15	System MI-COM.	For Z738
IC2	TDA7407	E-VOL. & N.C. MPX	
IC3	M5237ML	AVR IC	IC is combined with Q4, and it works as the error detection, the Q4's driver.
IC4	TDA7560	Power IC	
IC5	TDA7401	High pass filter & Non-Fader volume	HPF(Front/Rear output), LPF, Non-Fader switching and volume function
IC6	ICL7660SIBA	-9V AVR	DC/DC converter, -9V output for pre-output amplifier
IC7	TC74HC02AF	Mute logic	2-input NOR x 4
IC8	NJM4565M-TE2	Op. amp.	Amplifier for the spectrum analyser and generation of Vref.(1/2Vcc) voltage
IC10	NJM4565M-TE2	Op. amp.	Amplifier for the front pre-outputs
IC11	NJM4565M-TE2	Op. amp.	Amplifier for the non-fader pre-outputs
IC12	NJM4565M-TE2	Op. amp.	Amplifier for the rear pre-outputs
IC14	TDA7479D	RDS decoder	
IC16	S-80837ANNP	Reset IC	When BU 5V voltage is less than 3.7V, IC outputs Lo.
IC20	BA3121F	Isolation amplifier	AUX inputs isolation amplifier
IC21	BA3129F	Switched op.amp.	Input switching with AUX inputs and CD inputs
IC23	SI-8033JD	MECHA. AVR	DC/DC converter, +5V output for CD mechanism adapted for MP3/WMA
IC24	LT1930A	OEL AVR	DC/DC converter, +16V output for OEL module
IC25	BR24C02F-W	EEPROM	
Q1	2SD2375	CD servo AVR	AVR for CD mechanism servo operation, +7.5V output.
Q3	2SA1037K	SW 5V	While a base goes Lo, SW 5V is supplied to the microprocessor peripheral circuits.
Q4	2SA2057	A.+8V AVR	Q4 is combined with IC3, and it works as the power supply of +8.0V output.
Q5	DTC144EUA or UN5213	A.+8V AVR SW	When Q5's base goes Hi, Q6 is turned on, and A.+8V AVR is working.
Q6	DTA124EUA or UN5112		
Q7	DTA124EUA or UN5112	SW14V	When Q8's base goes Hi, Q7 is turned on, and A.+8V AVR, CD servo AVR and A.+10V AVR are working.
Q8	DTC124EUA or UN5212		
Q9	2SB1427	PAN5V SW	For PAN5V on/off switching. When a base goes Lo with panel attached to the set, Q9 is turned on, and PAN5V is supplied to the panel.
Q10	2SA2057	OEL/Illumination AVR	When Q11's base goes Hi, AVR outputs +9V.
Q11	2SC4081		
Q12	DTC124EUA or UN5212	OEL/Illumination AVR SW	When Q12's base goes Hi, Q13 is turned on, and OEL/Illumination AVR is working.
Q13	DTA124EUA or UN5112		
Q14	DTA123JK or KRA105S	EXT. AMP CON. SW	When a base goes Lo, Q14 is turned on, and control pulse signal is outputted.
Q15	DTC144EUA or UN5213	Dimmer detection SW	When vehicle small lamps turn on, Q15's base goes Hi, and it is turned on.

KDC-X959/Z939,Z738,Z838W

COMPONENT DESCRIPTION

Ref.No.	Component Name	Application/Function	Operation/Condition/Compatibility
Q16	2SB1443	A.+10V AVR	When Q17's base goes Hi, AVR outputs +10V.
Q17	2SC4081		
Q18	2SA1576A	PRE-AMP -9V AVR	Q18 and Q20 work as a differential amplifier, Q19 works as a driver, and -9.3V is supplied to OP AMP.
Q19	2SC4081		
Q20	2SA1576A		
Q21	2SC4081	PRE-AMP +9V AVR	Q21 and Q22 work as a differential amplifier, Q23 works as a driver, and +9.7V is supplied to OP AMP.
Q22	2SC4081		
Q23	2SA1576A		
Q26	2SB1277(Q,R)	P-CON SW	When Q29's base goes Hi, Q26 is turned on, and P-CON signal is outputted. Works during POWER ON mode.
Q29	DTC114YUA or UN5214		
Q27	2SA1576A	P-CON. protection SW	Protect Q26 by turning ON when P-CON output is grounded.
Q28	DTA124EUA or UN5112	P-CON. protection inhibit SW	Prevents Q27 tuning ON during start-up after power ON.
Q30	2SC4081	BU detection SW	While BACKUP is applied, a base goes Hi, and Q30 is turned on. When momentary power down has detected, a base goes Lo, and Q30 is turned off.
Q31	2SC4081	ACC detection SW	While ACC is applied, a base goes Hi, and Q31 is turned on.
Q32	DTA124EUA or UN5112	Mute driver for R Ch.	When BU detection SW or System RESET or MI-COM.'s MUTE is working, a base goes Lo, and Q32 and Q33 are turned on.
Q33	DTA124EUA or UN5112	Mute driver for L Ch.	
Q34	2SC4081	AGC for spectrum analyser	
Q35	DTC124EUA or UN5212	E. VOL. mute SW	When BU detection SW or MI-COM.'s mute is working, a base goes Hi, and Q35 is turned on.
Q36	DTC143TUA or UN5216	Noise buffer	
Q37	DTC143TUA or UN5216	Audio mute SW (Front L)	When Q37's base goes Hi, Pre-output is muting.
Q38	DTC143TUA or UN5216	Audio mute SW (Front R)	When Q38's base goes Hi, Pre-output is muting.
Q39	DTC143TUA or UN5216	Audio mute SW (Non Fader R)	When Q39's base goes Hi, Pre-output is muting.
Q40	DTC143TUA or UN5216	Audio mute SW (Non Fader L)	When Q40's base goes Hi, Pre-output is muting.
Q41	DTC143TUA or UN5216	Audio mute SW (Rear L)	When Q41's base goes Hi, Pre-output is muting.
Q42	DTC143TUA or UN5216	Audio mute SW (Rear R)	When Q42's base goes Hi, Pre-output is muting.
Q43	DTC124EUA or UN5212	FM+B SW	When Q43's base goes Hi, Q44 is turned on, and A.+8V is supplied to the F/E. Works during FM reception mode or RDS reception mode.
Q44	CPH3105		
Q45	DTC124EUA or UN5212	AM+B SW	When Q45's base goes Hi, Q46 is turned on, and A.+8V is supplied to the F/E. Works during AM reception mode.
Q46	CPH3105		
Q52	DTC143TUA or UN5216	Composite signal buffer	
Q101	DTA114YUA or UN5114	DSI LED SW	When a base goes Lo, Q101 is turned on, and DSI illumination LED is lit.
Q103	DTC124EUA or UN5212	AUX/CD selector SW	When a base goes Hi, AUX inputs are selected. When a base goes Lo, CD inputs are selected.
Q111	2SB1277(Q,R)	P-ANT SW	When Q112's base goes Hi, Q111 is turned on, and P-ANT signal is outputted. Works during FM/AM reception mode or RDS reception mode.
Q112	DTC114YUA or UN5214		
Q201	2SC4081	BU5V discharge SW	When BU OFF is detected, Q201 is turned on during the base Hi condition.
Q305	DTA114YUA or UN5114	EJECT LED SW	When a base goes Lo, Q305 is turned on, and EJECT illumination LED is lit.
Q306	DTA114YUA or UN5114	EJECT LED SW	When a base goes Lo, Q306 is turned on, and EJECT illumination LED is lit.
Q472	DTC144EUA or UN5213	MECHA. AVR SW	When a base goes Hi, Q472 is turned on, and MECHA. AVR operation stops.
Q473	2SC4081	BU 5V AVR	While BACKUP is applied, AVR outputs +5V. Q473 and Q474 are inverted Darlington connection.
Q474	2SA2057		
Q475	2SC4081	Voltage converter	Q475 and Q476 work as voltage coverter for BU 5V AVR, and it output +9V.
Q476	2SA2057		
Q703	2SA2057	OEL PAN5V AVR	While BACKUP is applied, AVR outputs +5V. Q703 and Q704 are inverted Darlington connection.
Q704	2SC4081		

MICROCOMPUTER'S TERMINAL DESCRIPTION

● IC8 (SWITCH UNIT: X16-169X-XX)

Pin No.	Pin Name	I/O	Description	Processing Operation
1-7	D14-D8	I/O	Data input/output with OEL, SRAM IC and ROM IC	
8	PAN3.3VDD	-	Positive power supply connection terminal	Connected to 3.3V lines.
9	VSS	-	Ground connection terminal	Connected to GND lines.
10-17	D7-D0	I/O	Data input/output with OEL, SRAM IC and ROM IC	
18	MODE2	I		Not used(Pull down to GND lines)
19-21	NC	O		Not used(N.C.)
22	RSTB_OEL	I/O	Reset output to OEL	Lo: Reset, Hi-Z: Normal operation
23,24	NC	I/O		Not used(N.C.)
25	SRAM_TESTI	I	SRAM test terminal	Not used(Pull down to GND lines)
26	SRAM_TESTO	O	SRAM test terminal	Not used(N.C.)
27	PAN3.3VDD	-	Positive power supply connection terminal	Connected to 3.3V lines.
28	VSS	-	Ground connection terminal	Connected to GND lines.
29-33	KR1-5	I	Key return input 1-5	
34	NC	O		Not used(N.C.)
35	SRAM_CH	O		Not used(N.C.)
36	16V OEL, ILL BLUE	I/O	LED, OEL AVR ON/OFF control output	Hi-Z: AVR OFF, Hi: AVR ON
37	PAN3.3VDD	-	Positive power supply connection terminal	Connected to 3.3V lines.
38	VSS	-	Ground connection terminal	Connected to GND lines.
39	NC	O		Not used(N.C.)
40-43	KS4-1	I/O	Key scan output 4-1	Lo: Scan ON, Hi-Z: Scan OFF
44,45	NC	O		Not used(N.C.)
46	NMI	I		Not used(Connected to GND lines)
47	PAN3.3VDD	-	Positive power supply connection terminal	Connected to 3.3V lines.
48	VSS	-	Ground connection terminal	Connected to GND lines.
49	CE_SD	O	Data line chip select output to IC9	Hi: SCDATA output enable
50	NC	O		Not used(N.C.)
51	SCREQ	O	Communication request output to the system MI-COM.	Lo: Standby, Hi: Request
52	NC	O		Not used(N.C.)
53	MCREQ	I	Communication request input from the system MI-COM.	Hi: Request
54,55	NC	O		Not used(N.C.)
56	FCS	I/O	CS output to the flush ROM IC	Lo: Chip select
57	MODE1	I		Not used(Pull down to GND lines)
58	MODE0	I		Not used(Pull down to GND lines)
59	PARST	I	Reset input	Lo: Reset
60	CKSEL	I	Clock generator operation mode setting terminal	Connected to GND lines.
61	CVDD	-	Positive power supply connection terminal	Connected to 3.3V lines.
62	X2	-	Main clock resonator connection terminal	
63	X1	I	Main clock resonator connection terminal	
64	CVSS	-	Ground connection terminal	Connected to GND lines.
65	MCCLK	I	Clock input from the system MI-COM.	
66	MCDATA	I	Data input from the system MI-COM.	
67	SCDATA	O	Data output to the system MI-COM.	
68	FCLK	O	Write clock output to the flush ROM IC	
69	FDATAIN	I/O	Data input from the flush ROM IC	
70	FDATAOUT	O	Data output to the flush ROM IC	
71	AVDD	-	A/D converter positive power supply connection terminal	Connected to 3.3V lines.
72	AVSS	-	A/D converter ground connection terminal	Connected to GND lines.
73	ANI7	I	A/D converter analogue input terminal	Not used(Connected to GND lines)
74	WAVE IN	I	Audio input	
75	F06	I	BPF(10kHz) input	
76	F05	I	BPF(3.3kHz) input	
77	F04	I	BPF(1kHz) input	
78	F03	I	BPF(330Hz) input	
79	F02	I	BPF(150Hz) input	
80	F01	I	BPF(63Hz) input	
81	PAN3.3VDD	-	Positive power supply connection terminal	Connected to 3.3V lines.

KDC-X959/Z939,Z738,Z838W

MICROCOMPUTER'S TERMINAL DESCRIPTION

Pin No.	Pin Name	I/O	Description	Processing Operation
82	VSS	-	Ground connection terminal	Connected to GND lines.
83	NC	O		Not used(N.C.)
84	SARST	O	Reset output to the BPF IC	Hi: Reset
85	REMO	I	Data input from the remote control light sensor	
86	NC	I		Not used(N.C.)
87	FROM_CH	O		Not used(N.C.)
88	NC	I		Not used(N.C.)
89,90	NC	O		Not used(N.C.)
91	RDY/RV	I	RDY signal input	
92-94	NC	O		Not used(N.C.)
95	OE/RD	I/O	Read control output to OEL, SRAM IC and ROM IC	Lo: Read, Hi-Z: Other
96	WE/WR	I/O	Write control output to OEL and SRAM IC	Lo: Write, Hi-Z: Other
97	UWE/LWR	I/O	Write control output to OEL and SRAM IC	Lo: Write, Hi-Z: Other
98	PAN3.3VDD	-	Positive power supply connection terminal	Connected to 3.3V lines.
99	VSS	-	Ground connection terminal	Connected to GND lines.
100	RESET ROM	I/O	Reset output to the ROM IC	Lo: Reset, Hi-Z: Normal operation
101	WP ROM	I/O	Boot block, Write protect	Lo: Write, Hi-Z: Other
102,103	NC	O		Not used(N.C.)
104	CS ROM	O	CS output to the ROM IC	Lo: Chip enable
105	NC	O		Not used(N.C.)
106	CS RAM	O	CS output to the SRAM IC	Lo: Chip select
107	CS OEL	O	CS output to OEL	Lo: Chip select
108	UBE	I/O	Bus enable output of D8-D15	Lo: Permission, Hi-Z: Inhibit
109	LBE	I/O	Bus enable output of D0-D7	Lo: Permission, Hi-Z: Inhibit
110	RED	O	Illumination red ON/OFF output in case of two colours /Illumination ON/OFF output in case of one colour	Lo: ON, Hi: OFF
111	GREEN	O	Illumination green ON/OFF output in case of two colours /Not used in case of one colour	Lo: ON, Hi: OFF in case of two colours /Not used(N.C.) in case of one colour
112	PAN3.3VDD	-	Positive power supply connection terminal	Connected to 3.3V lines.
113	VSS	-	Ground connection terminal	Connected to GND lines.
114-117	NC	O		Not used(N.C.)
118-123	A20-A15	I/O	Address bus	
124	PAN3.3VDD	-	Positive power supply connection terminal	Connected to 3.3V lines.
125	VSS	-	Ground connection terminal	Connected to GND lines.
126-128	A14-A12	I/O	Address bus	
129	A11/RS	I/O	Address bus	
130-133	A10-A7	I/O	Address bus	
134	PAN3.3VDD	-	Positive power supply connection terminal	Connected to 3.3V lines.
135	VSS	-	Ground connection terminal	Connected to GND lines.
136-142	A6-A0	I/O	Address bus	
143	NC	I/O		Not used(N.C.)
144	D15	I/O	Data input/output with OEL, SRAM IC and ROM IC	

● IC1 (ELECTRIC UNIT: X25-9270-XX)

Pin No.	Pin Name	I/O	Description	Processing Operation
1	MC DATA	I/O	Data input/output with the panel MI-COM.	
2	MC CLK	O	Clock output to the panel MI-COM.	
3	DSI GUIDE	I/O	DSI control output	Lo: DSI ON, Hi-Z: DSI OFF Lights on at the panel tilted during POWER ON mode. Flashing at the panel detached during POWER ON mode.
4	EJECT KEY G	O	Eject key illumination green control output	Lo: ON, Hi-Z: OFF Lights on at the panel tilted during POWER ON mode in case of the key illumination green.
5	EJECT KEY R/G	O	Eject key illumination red/green control output	Lo: ON, H-Z: OFF Lights on at the panel tilted during POWER ON mode.
6	MC REQ/ FLIP DET	I/O	Communication request output to the panel MI-COM. /Flip detection input	Hi: Request /Lo: Panel detected, Hi: Panel attached

MICROCOMPUTER'S TERMINAL DESCRIPTION

Pin No.	Pin Name	I/O	Description	Processing Operation
7	IC2 SDA	I/O	Data input/output with IC2, IC5, and IC25	
8	IC2 SCL	I/O	Clock input/output with IC2, IC5, and IC25	
9	EVDD	-	Positive power supply connection terminal	Connected to BU 5V lines.
10	EVSS	-	Ground connection terminal	Connected to GND lines.
11	PAN RESET	O	Reset output to the panel MI-COM.	Lo: Reset or Momentary power down detected
12	BEEP	O	BEEP output	
13	REMO	I	Data input from the wired remote control	
14	SVR	O	SVR output	Not used(N.C.)
15	DIMMER	I	Small lights detection input	Lo: During vehicle small lamps turn on
16	PLL DATA	I/O	Data input/output with F/E	
17	PLL CLK	I/O	Clock input/output with F/E	
18	P-STBY	O	POWER IC STBY output	Lo: Power IC OFF, Hi: Power IC ON or ALL OFF mode
19	P-CON	I/O	P-CON output	Hi-Z: POWER OFF mode or ALL OFF mode, Hi: POWER ON mode
20	ANT-CON	O	ANT-CON output	Hi: During TUNER mode or last FM mode with RDS/RBDS mode!
21	TEST	-	Test terminal	Not used(Connected to GND lines)
22	P MUTE	O	POWER IC mute output	Lo: Muting during POWER OFF mode, ALL OFF mode and TEL MUTE ON
23	PAN5V	I/O	Panel 5V control output	Lo: Panel attached normally, Hi-Z: Panel detached or tilted
24	EXT-AMP-CON	O	External amp. control output (in 200msec)	Bass boost OFF__Hi: 160msec, Lo: 40msec Bass boost LOW__Hi: 130msec, Lo: 70msec Bass boost HI__Hi: 100msec, Lo: 100msec
25	CD MECHA+B	I/O	CD4.7V ON/OFF output	Lo: During CD source selected, Hi-Z: Except CD source selected
26	EMUTE	O		Not used(N.C.)
27	BU DET	I	Momentary power down detection input	Lo: BU ON, Hi: When momentary power down detected or BU OFF
28	ACC DET	I	ACC detection terminal	Lo: ACC ON, Hi: ACC OFF
29	SW5V	I/O	SW5V control terminal	Lo: SW5V ON, Hi-Z: SW5V OFF
30	MUTE	I/O	MUTE output	Lo: Muting OFF, Hi-Z: Muting ON
31	O CE	I/O	External display CE terminal	
32	O CLK	I/O	External display clock terminal	
33	O DATA	I/O	External display data terminal	
34	RESET	I	Reset input	Lo: System reset, Hi: Normal operation
35	XT1	I	Sub clock resonator connection terminal	Clock count during POWER OFF mode
36	XT2	-	Sub clock resonator connection terminal	
37	REGC	-	Capacitor connection terminal for regulator inside microprocessor	
38	X2	-	Main clock resonator connection terminal	Oscillation: POWER ON mode, Oscillation stop: POWER OFF mode or momentary power down detected
39	X1	I	Main clock resonator connection terminal	
40	VSS	-	Ground connection terminal	Connected to GND lines.
41	VDD	-	Positive power supply connection terminal	Connected to BU 5V lines.
42	CLKOUT	O	Internal system clock output	Not used(N.C.)
43	NC	O		Not used(N.C.)
44	E2PDET	I	EEPROM detection input	Lo: No EEPROM, Hi: With EEPROM
45	PRE MUTE L	O	Pre-out muting L Ch. control output	Lo: When M MUTE L input is Lo during CD source selected or Momentary power down detected, Hi: Fix in the case of 2 zone mode
46	PRE MUTE R	O	Pre-out muting R Ch. control output	Lo: When M MUTE R input is Lo during CD source selected or Momentary power down detected, Hi: Fix in the case of 2 zone mode
47	DSP DATA	O	Data output to DSP IC	Not used(N.C.)
48	DSP LATCH	O	Latch output to DSP IC	Not used(N.C.)
49	DSP CLK	O	Clock output to DSP IC	Not used(N.C.)

KDC-X959/Z939,Z738,Z838W

MICROCOMPUTER'S TERMINAL DESCRIPTION

Pin No.	Pin Name	I/O	Description	Processing Operation
50	AFS	O	Noise detection time constant switching terminal	Lo: During FM seek or AF search, Hi: During FM reception, Hi: During last FM mode with RDS/RDBS model
51	AM+B	I/O	AM+B control	Hi: During AM reception
52	FM+B	I/O	FM+B control	Hi: During FM reception, Hi: During last FM mode with RDS/RDBS model
53	R QUAL	I	Quality input from the RDS decoder IC	Except RDS, RBDS model: Not used(pull down to GND lines)
54	R DATA	I	Data input from the RDS decoder IC	Except RDS, RBDS model: Not used(pull down to GND lines)
55	IC2TYPE0	I	IC2 setting terminal	Lo: Initial value(default)
56	IC2TYPE1	I	IC2 setting terminal	Lo: Initial value(default)
57	P ON	I/O	SW 14V control output	Hi-Z: POWER OFF mode, Hi: POWER ON mode
58	BVDD	-	Positive power supply connection terminal	Connected to BU 5V lines.
59	BVSS	-	Ground connection terminal	Connected to GND lines.
60	TYPE0	I	Destination type selection terminal 0	
61	TYPE1	I	Destination type selection terminal 1	
62	TYPE2	I	Destination type selection terminal 2	
63	TYPE3	I	Destination type selection terminal 3	
64	AUX SW	O	CD/AUX input switching output	Lo: Except AUX input, Hi: AUX input
65	ILL ON	I/O	OEL/Illumination AVR ON/OFF control output	Hi-Z: AVR OFF, Hi: AVR ON
66	MOSW	O	CD mechanism loading motor control output	Hi: CD loading/eject action or Break, Lo: Other
67	LO/EJ	I/O	CD mechanism loading/Eject switching output	Lo: Loading, Hi: Eject, Hi-Z: Stop or Break
68	M STOP	O	Stop request to CD mechanism MI-COM.	Lo: Stop mode, Hi: Operation mode
69	M RST	O	Reset output to CD mechanism MI-COM.	Lo: Reset
70	CH CON	O	Changer control	Lo: Standby mode, Hi: Operation mode
71	CH RST	O	Reset output to changers	 : Reset
72	CH REQH	O	Request output to changers	Lo: Request
73	AVCONT	O	A/D converter reference voltage control output	Hi: Active, Connected to AVREF terminal
74	AVDD	-	A/D converter positive power supply connection terminal	Connected to BU 5V lines.
75	AVSS	-	A/D converter ground connection terminal	Connected to GND lines.
76	AVREF	I	A/D converter reference voltage input terminal	
77	IFC OUT	I	F/E IFC OUT input terminal	Hi: Station detected (Vth=2.5V)
78	S METER	I	S-meter input from F/E	
79	NOISE	I	FM noise detection input	
80,81	NC	I		Not used(Pull down to GND lines)
82	CD SW2	I	12cm disc detection SW input	Lo: 12cm disc detected
83	M MUTE R	I	Mute request (R Ch.) from CD mechanism MI-COM.	Lo: Mute request
84	M MUTE L	I	Mute request (L Ch.) from CD mechanism MI-COM.	Lo: Mute request
85	CD SW3	I	Down & limit switch detection input	Hi: Chucking, Hi → Lo: Pickup most inner position
86	PANEL DET	I	Panel detection input	Lo: Panel attached, Hi: Panel detached
87	CH MUTE	I	Mute request from changers	Hi: Mute request
88	PHONE	I	PHONE detection input	1V or less: TEL MUTE, 2.5V or greater: NAVI MUTE
89	SC CON	O	Control output to the panel MI-COM.	Hi: Operation mode
90	SOURCE	I/O	SOURCE key detection input	Lo: When SOURCE key is pressed
91	CD SW1	I	Loading SW detection input	Lo: Loading start
92	CD SW4	I/O	8cm disc detection SW input	Not used(N.C.)
93	R CLK	I	Clock input from the RDS decoder IC	Except RDS, RBDS model: Not used(pull down to GND lines)
94	CH REQC	I	Communication request input from changers	Lo: Request
95	EJECT	I	EJECT key detection input	Lo: When EJECT key is pressed
96	SC REQ	I	Communication request input from the panel MI-COM.	Hi: Request
97	CH DATA C	I	Data input from changers	
98	CH DATA H	O	Data output to changers	
99	CH CLK	I/O	Clock input/output with changers	
100	SC DATA	I	Data input from the panel MI-COM.	

TEST MODE

1. How to enter the test mode

While pressing and holding the Preset 1 and Preset 3 keys, reset the unit.

2. How to exit from the test mode

Reset the unit, ACC OFF, power OFF and Panel detached.
(Note) The test mode cannot be terminated by momentary power down.

3. Initial status in the test mode

- Sources : ALL OFF
- Display : All segments are lit.
- Volume : -10 dB (displayed as "30")
- Loudness : OFF
- CRSC : OFF regardless of the presence of switching function.
- SYSTEM Q : Flat
- BEEP : When pressing any keys, the buzzer generates a beep at any time.

4. Special display in Tuner mode

When any of the following messages is displayed in Tuner mode, the F/E may be abnormal.

- "TNE2P NG": The EEPROM is set to the default (unstable values) because the F/E was shipped without passing through the adjustment process, etc.
- "TNCON NG": Communication with the F/E is not possible.

5. Forced switching of K3I

Each press of the Preset 6 key in Tuner mode should switch K3I from AUTO → Forced Wide → Forced Middle → Forced Narrow → AUTO.

The initial status is AUTO and the display shows these modes as follows.

- AUTO : FMA
- Forced Wide : FMW
- Forced Middle : FMM
- Forced Narrow : FMN

6. Test mode specifications of the CD receiver

- Forced ejection is inhibited in the reset start operation.
When the unit is reset while a CD is loaded in it, the CD is not recognized by resetting.
- Each press of the Track Up key jumps to the following track numbers:
No. 9 → No. 15 → No. 10 → No. 11 → No. 12 → No. 13 → No. 14 → No. 9 (The cycle restarts from here.)
- Each press of the Track Down key jumps to the previous track number to the track being played.
- When the number of total tracks of the MP3 disc or the WMA disc is less than 9, 1st track is played.

- When the model is equipped the CD mechanism assembly adapted for MP3 or MP3/WMA disc, the mechanism name and version number are displayed during the CD source selecting.
- When the disc media is CD, A short press of the Preset 1 key jumps to the track number 28.

7. Audio-related specifications

- A short press of the Q key initiates the audio adjustment mode.
- Pressing the * key on the remote initiates the audio adjustment mode.
- Fader is selected to the initial item.
- Continuous holding of a remote control key is inhibited.
- Bass, Middle and Treble are adjusted in 3 steps of Min / Center / Max with the Track Up/Down keys.
- Balance is adjusted in 3 steps of Left Max / Center / Right Max with the Track Up/Down keys.
- Fader is adjusted in 3 steps of Rear Max / Center / Front Max with the Track Up/Down keys.
- HPF is adjusted in 2 steps of Through / 220Hz with the Track Up/Down keys.
- LPF is adjusted in 2 steps of Through / 120Hz with the Track Up/Down keys.
- Bass f, Bass Q, Bass EXT, Middle f, Middle Q and Treble f are not dealt with by the audio adjust.

8. Menu-related specifications

- Pressing the DNPP/SBF key on the remote initiates the Menu mode.
- Continuous holding of a remote control key is inhibited.
- In the case of the CD receiver model, A short press of the PLAY/PAUSE key initiates the Menu mode.

9. Backup current measurement

When the unit is reset while ACC is OFF (i.e. by turning Backup ON), the MUTE terminal goes OFF in 2 seconds in place of 15 second. (The CD mechanism is not activated at this time.)

TEST MODE

10. Special display when the display is all on

Pressing the Preset keys while the power is ALL OFF displays the following information.

PRESET 1	Version display (8 digits, Month/Day/Hour/Minute) (Display) SYS xxxxxxxx : System microcomputer PAN xxxxxxxx : Panel microcomputer
PRESET 2	Sireal number display (8 digits) (Display) SNo xxxxxxxx
PRESET 3	Short press : View power ON time. (The All OFF period is not counted.) Long press/hold : Clear power ON time at the power ON time displaying. (Display) PonTim xxxxx Max. 65535 (hours)
PRESET 4	Short press : Display CD operation time. Long press/hold : Clear CD operation time at the CD operation time displaying. (Display) CDTIME xxxxx Max. 65535 (hours)
PRESET 5	Short press : Display CD ejection count. Long press/hold : Clear CD ejection count at the CD ejection count displaying. (Display) EjeCnt xxxxx Max. 65535 (times)
PRESET 6	Short press : Display Panel open/close count. Long press/hold : Clear Panel open/close count at the Panel open/close count. (Display) PnCnt xxxxx Max. 655350 (times)

11. Method of the span switching (K and M type only)

While holding the Preset 1 and Preset 5 keys, reset the unit.

12. Other specifications

- No displays such as "CODE OFF" during Power-ON.
- Pressing the TI (AUTO) key during changer operation turns on 2zone. Cancel by pressing the TI (AUTO) key again. The P/S dot is lit during 2zone.
- In the case of 2 PREOUT model with Non Fader output, Each pressing and holding the ATT key for 1 second or more during All OFF, Non Fader output is switching Rear output or Non Fader output.
- In the case of 2 colors key illumination model, Each press the ATT key during All OFF, the key illumination is switching Green or Red.

■ Security-related information

1. Forced Power ON mode (All models)

Even when the security (Cord) is approved, resetting the unit while holding the ATT and Preset 4 keys makes it possible to turn the power ON for 30 minutes.

After 30 minutes have elapsed, it is not possible to return to the previous condition unless the unit is reset again.

2. Method of registration of the security code after EEPROM (Tuner Unit Ass'y) replacement (Code security model)

1. Enter the test mode. (See 1. How to enter the test mode)

2. Press the PLAY/PAUSE key to enter the Menu mode.

3. When the message "Security" is displayed, press and hold the Track Up/Down key for 1 second to enter the security registration mode.

4. Enter the code using the FM/AM/Track Up/Track Down keys.

- FM key : Number up
- AM key : Number down
- Track Up key : Cursor right shift
- Track Down key : Cursor left shift

5. Hold down the Track Up key for at least 3 seconds and the message, "RE-ENTER" appears, so once again enter the code according to Step 4 above.

6. Press and hold the Track Up key for 3 seconds until "APPROVED" is displayed.

7. Exit from the test mode. (See 2. How to exit from the test mode)

(Note) All Clear is not applicable to the security code of this model.

3. Simple way to clear the security code (K type only)

1. During code request mode, press the VOL UP key for at least 3 seconds while holding down the DISP key. (---- will disappear)

2. Enter, "KCAR" with the remote controller as described below. (Same as on 01 model.)

- Press the remote controller 5 key twice, and press the Track Up key. (Enters a "K")
- Press the remote controller 2 key three times, and press the Track Up key. (Enters a "C")
- Press the remote controller 2 key once, and press the Track Up key. (Enters an "A")
- Press the remote controller 7 key twice, and press the Track Up key. (Enters an "R")

3. Security function is canceled and unit sets to All-Off mode.

4. Code request mode appears if a mistake was made in entering the numbers.

PC BOARD (Component Side View)

PC BOARD (Foil Side View)

SWITCH UNIT

DAUGHTER UNIT

DAUGHTER UNIT

SWITCH UNIT

SWITCH UNIT (X16-169X-XX)

Ref. NO.	IC	Q	Address
2			4B
3			2B
5			3B
6			5B
10			5B
	4		6B
	5		6B
	9		6B

X16-169X-XX (J74-1336-12)

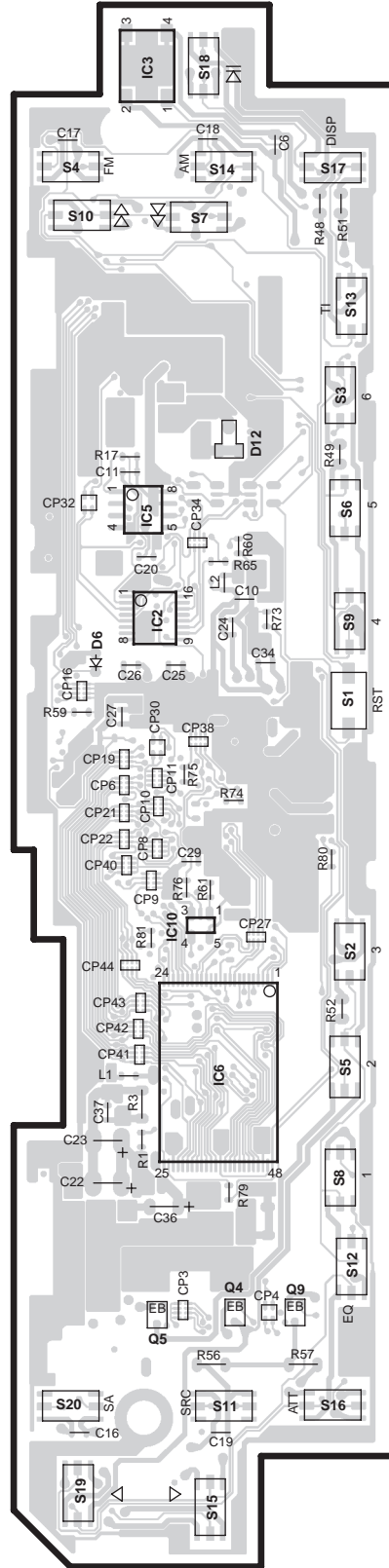

X89-253X-XX (J74-1332-12)

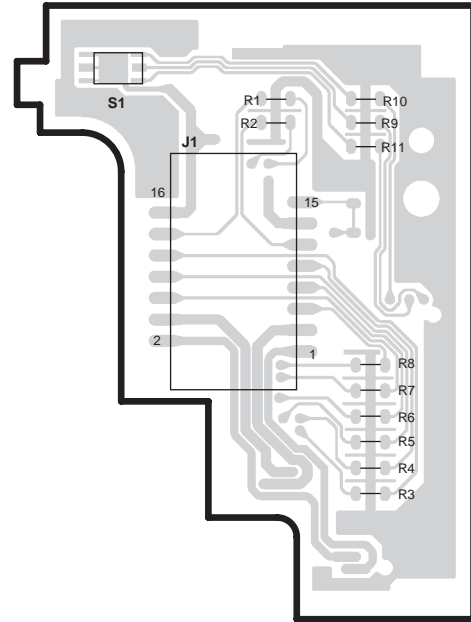

X89-253X-XX (J74-1332-12)

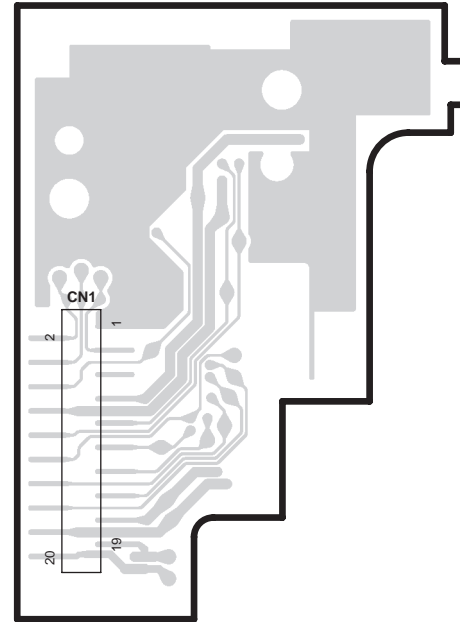

X16-169X-XX (J74-1336-12)

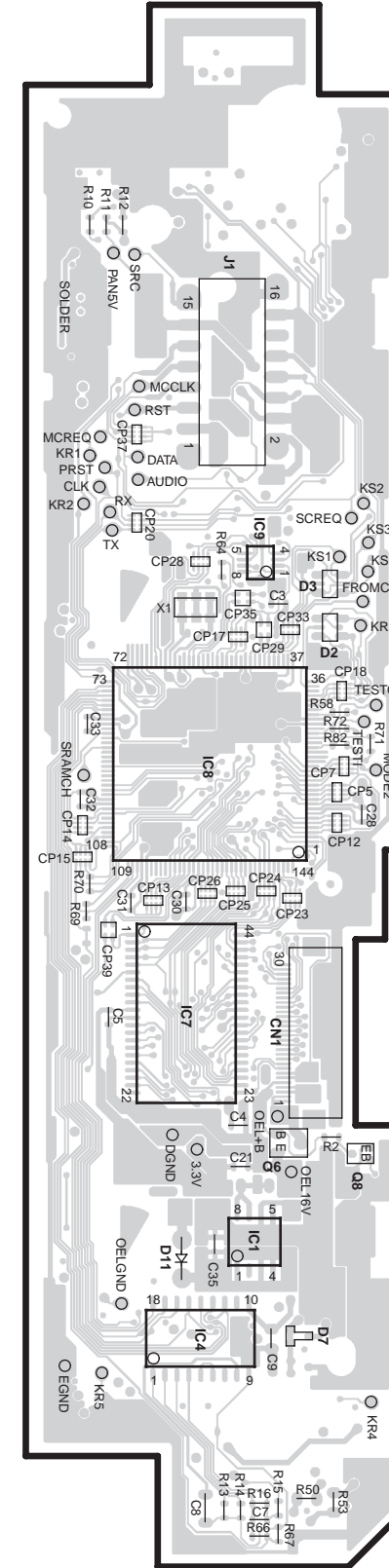

SWITCH UNIT (X16-169X-XX)

Ref. NO.	IC	Q	Address
1			6H
4			6H
7			5H
8			4H
9			3H
	6		5H
	8		5H

Refer to the schematic diagram for the values of resistors and capacitors.

PC BOARD (Component Side View)

ELECTRIC UNIT

ELECTRIC UNIT
(X25-927X-XX)

X25-927X-XX (J74-1328-22)

Ref. NO.		Address
IC	Q	
1		5N
2		3M
3		3L
4		4P
5		3N
6		4O
7		4O
8		4M
10		3O
11		3O
12		3N
14		3M
16		5O
20		4M
21		4M
23		5P
24		5L
1		3L
4		2L
5		3L
6		3L
7		3L
8		3L
10		4L
11		4L
12		3L
13		3L
16		3O
17		3O
19		4N
20		3N
22		3O
23		4O
26		5P
29		4P
30		5P
34		3M
35		3M
52		2M
101		6N
111		5P
305		6O
306		6O
472		6O
473		5Q
474		5Q
475		5Q
476		5Q
703		4L

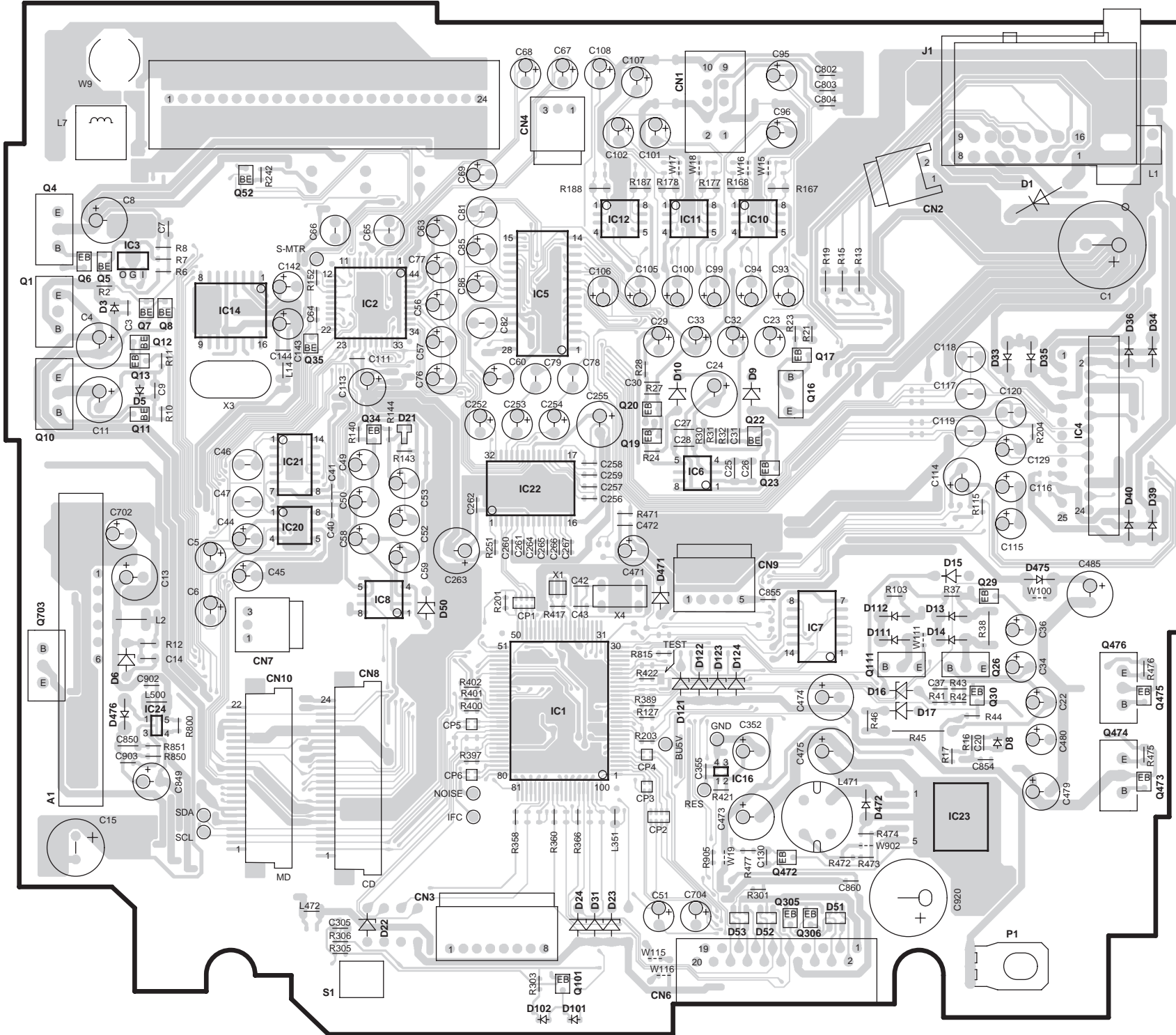

Refer to the schematic diagram for the values of resistors and capacitors.

PC BOARD (Foil Side View)

ELECTRIC UNIT

X25-927X-XX (J74-1328-22)

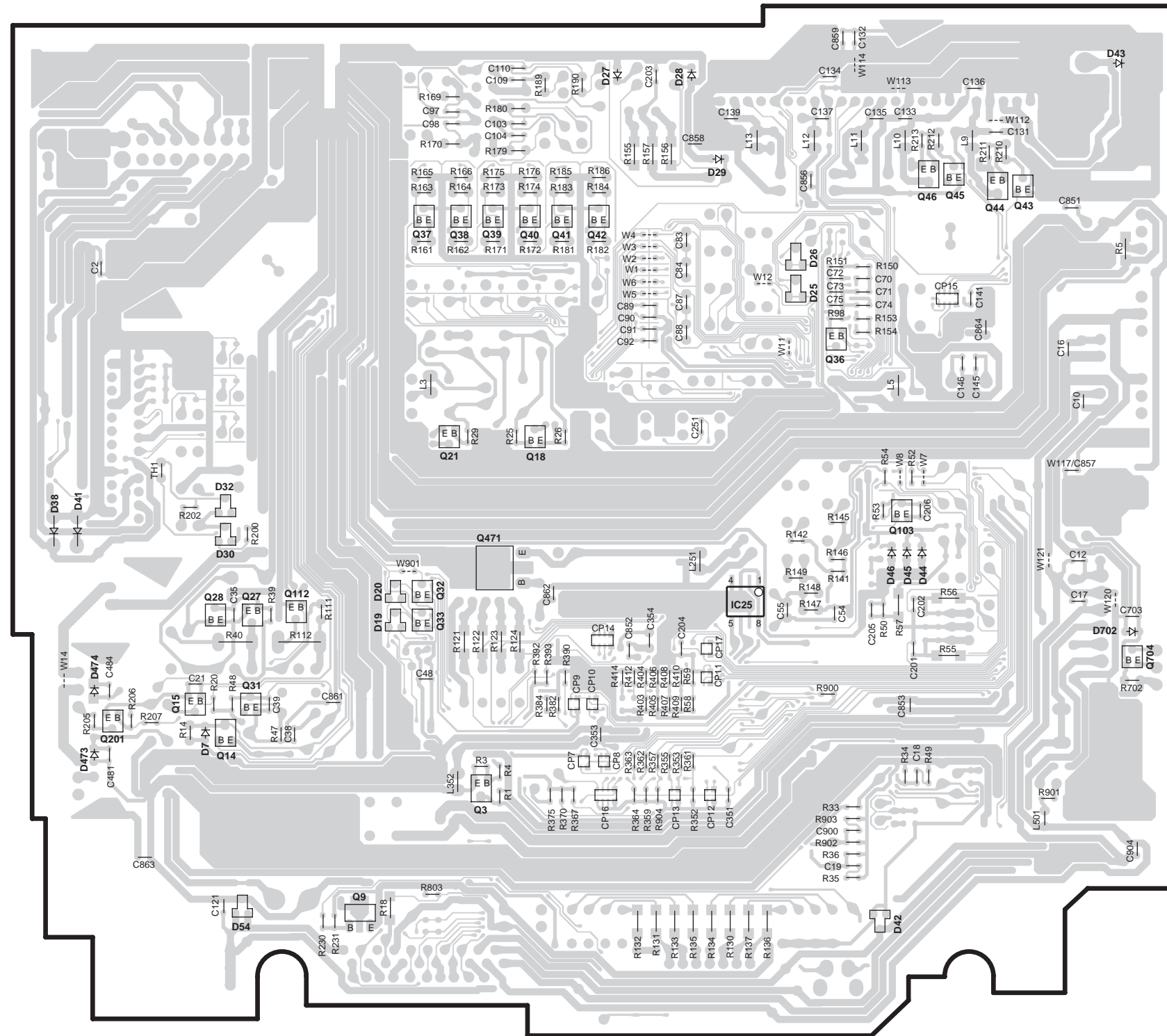

ELECTRIC UNIT (X25-927X-XX)

Ref. NO.	IC	Q	Address
25			4W
		3	5V
		9	6V
		14	5U
		15	5U
		18	4V
		21	4V
		27	4U
		28	4U
		31	5U
		32	4V
		33	4V
		36	3X
		37	3V
		38	3V
		39	3V
		40	3V
		41	3W
		42	3W
		43	2Y
		44	2Y
		45	2X
		46	2X
		103	4X
		112	4U
		201	5T
		704	5Y

Refer to the schematic diagram for the values of resistors and capacitors.

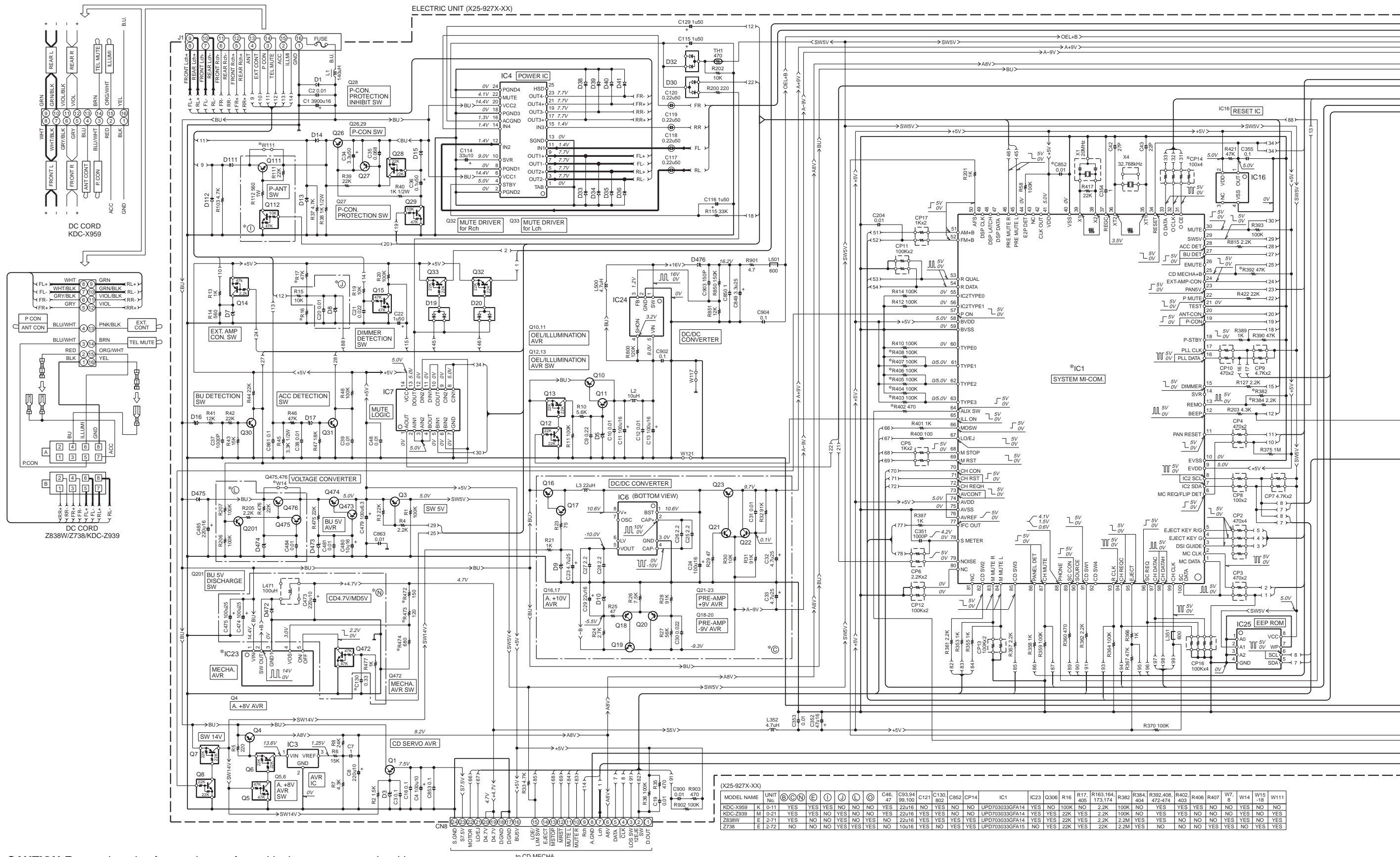

CAUTION: For continued safety, replace safety critical components only with manufacturer's recommended parts (refer to, parts list). ⚠ Indicates safety critical components. To reduce the risk of electric shock, leakage-current or resistance measurements shall be carried out (exposed parts are acceptably insulated from the supply circuit) before the appliance is returned to the customer.

DC voltages are as measured with a high impedance voltmeter. Values may vary slightly due to variations between individual instruments or/and units.

DTA123JK UN5213
 DTC114YUA UN5214
 DTC143TUA UN5216
 UN5111 2SA1576A
 UN5114

2SB1277(Q,R)
 2SB1443

2SA1037K
 2SC4081

DTA124EUA
 DTC114EUA
 DTC123JUA
 DTC124EUA
 DTC144EUA

NJM4565M-TE2

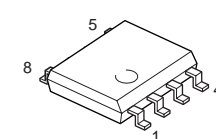
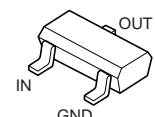
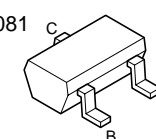
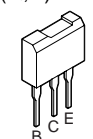

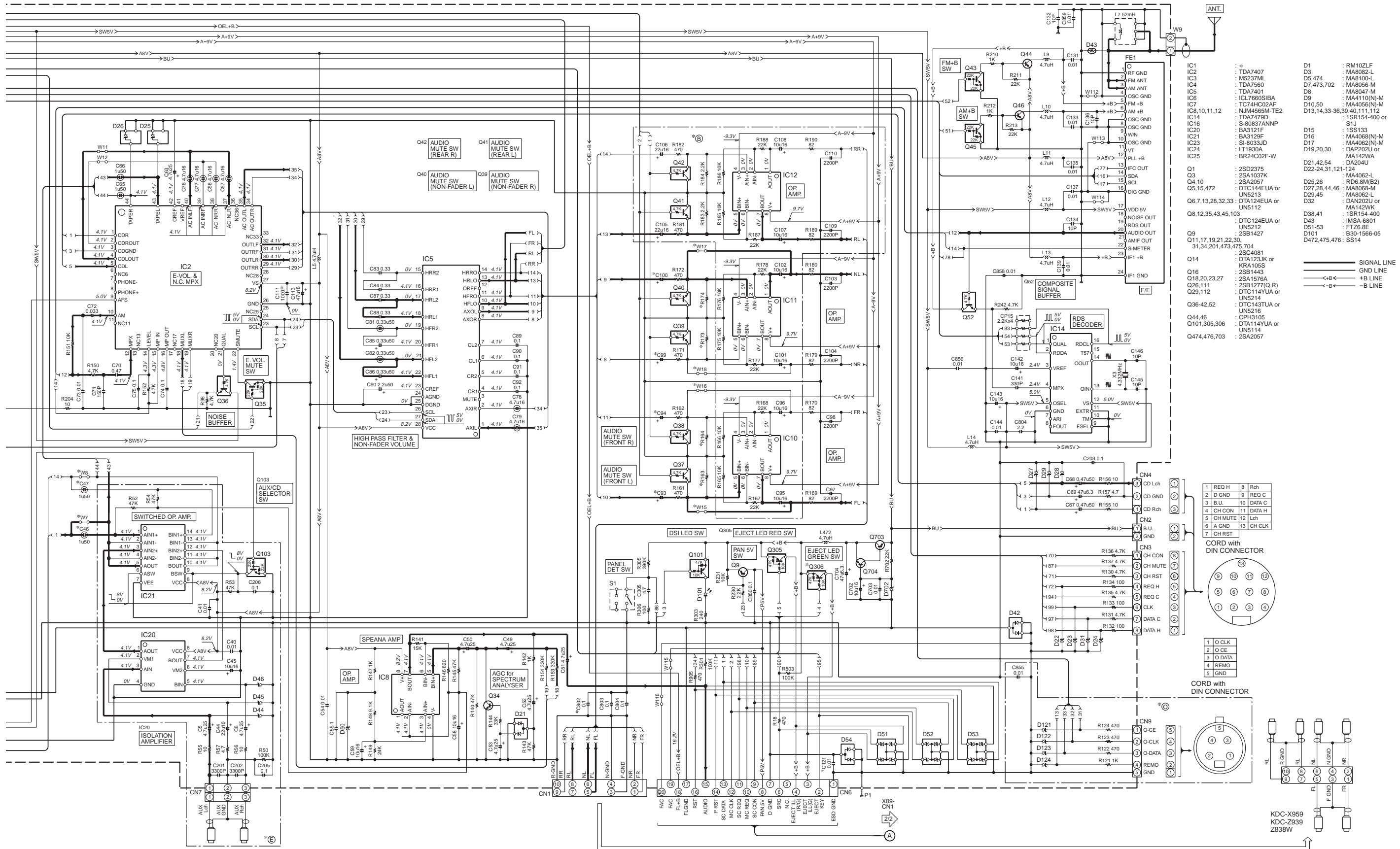

- IC1 : TDA7407
 - IC2 : M5237ML
 - IC3 : TDA7560
 - IC4 : TDA7401
 - IC5 : TDA7401
 - IC6 : ICL7660SIBA
 - IC7 : TC74HC02AF
 - IC8,10,11,12 : NUM4565M-TE2
 - IC14 : TDA749D
 - IC16 : S-80837ANP
 - IC20 : BA3121F
 - IC21 : BA3129F
 - IC23 : SI-8033JD
 - IC24 : LT1930A
 - IC25 : BR24C02F-W
- D1 : RM10ZLF
 - D3 : MA8082-L
 - D5,474 : MA8100-L
 - D7,473,702 : MA8056-M
 - D8 : MA8047-M
 - D9 : MA4110(N)-M
 - D10,50 : MA4056(N)-M
 - D13,14,33-36,39,40,111,112 : SR154-400 or S1U
- D15 : 1S5133
 - D16 : MA4068(N)-M
 - D17 : MA4062(N)-M
 - D19,20,30 : DAP202U or MA142WA
 - D21,42,54 : DA204U
 - D22-24,31,121-124 : MA4062-L
 - D25,26 : RD6.8M(B2)
 - D27,28,44,46 : MA8063-M
 - D29,45 : MA8062-L
 - D32 : DAN202U or MA142WK
 - D38,41 : 1SR154-400
 - D43 : IMSA-6801
 - D51-53 : FT26.8E
 - D101 : B30-1566-05
 - D472,475,476 : SS14
- Q1 : 2SD2375
 - Q3 : 2SA1037K
 - Q4,10 : 2SA2057
 - Q5,15,472 : DTC144EUA or UN5213
 - Q6,7,13,28,32,33 : DTA124EUA or UN5112
 - Q8,12,35,43,45,103 : 2SC4081
 - Q9 : 2SB1427
 - Q11,17,19,21,22,30,31,34,201,473,475,704 : DTC124EUA or UN5212
 - Q14 : DTA123JK or KRA105S
 - Q16 : 2SB1443
 - Q18,20,23,27 : 2SA1576A
 - Q26,111 : 2SB1277(O,R)
 - Q23,112 : DTC114YUA or UN5214
 - Q36-42,52 : DTC143TUA or UN5216
 - Q44,46 : CPH3105
 - Q101,305,306 : DTA114YUA or UN5114
 - Q474,476,703 : 2SA2057

— SIGNAL LINE
 — GND LINE
 — +B LINE
 — -B LINE

1	REQ H	8	Rch
2	D GND	9	REQ C
3	B.U.	10	DATA C
4	CH CON	11	DATA H
5	CH MUTE	12	Lch
6	A GND	13	CH CLK
7	CH RST		

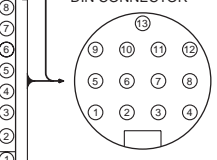

1	CLK
2	OE
3	DATA
4	REMO
5	GND

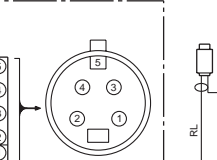

KDC-X959
 KDC-Z939
 Z838W

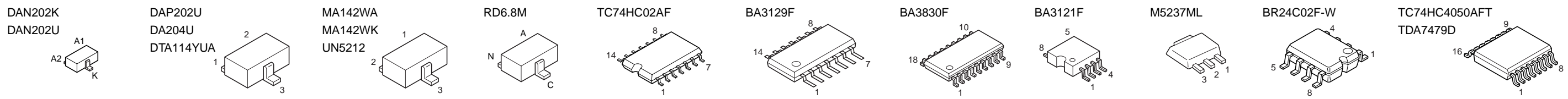

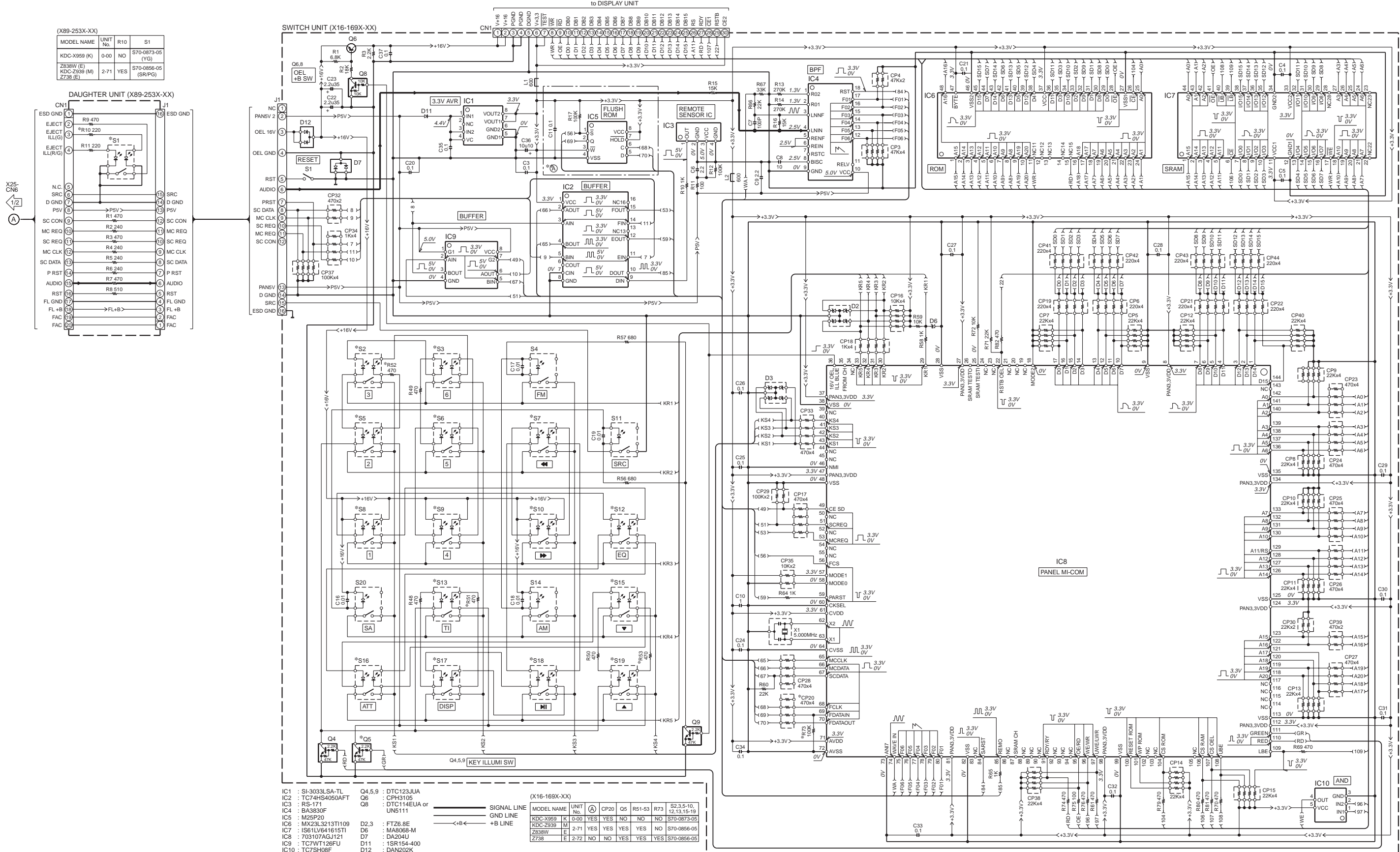

CAUTION: For continued safety, replace safety critical components only with manufacturer's recommended parts (refer to, parts list). ⚠ Indicates safety critical components. To reduce the risk of electric shock, leakage-current or resistance measurements shall be carried out (exposed parts are acceptably insulated from the supply circuit) before the appliance is returned to the customer.

DC voltages are as measured with a high impedance voltmeter. Values may vary slightly due to variations between individual instruments or/and units.

EXPLODED VIEW

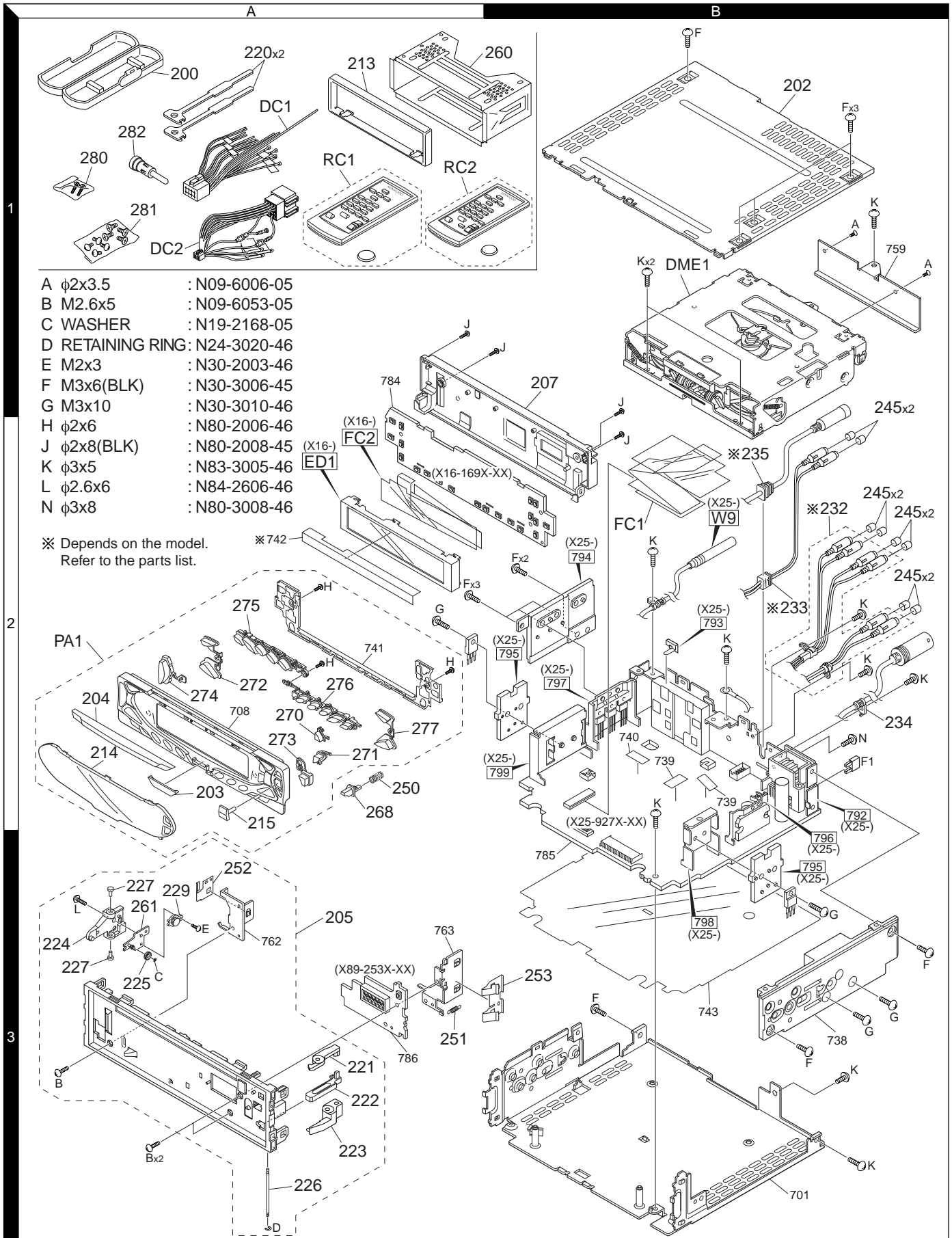

Parts with exploded numbers larger than 700 are not supplied.

KDC-X959/Z939,Z738,Z838W

PARTS LIST

* New Parts

Parts without Parts No. are not supplied.

Les articles non mentionnes dans le Parts No. ne sont pas fournis.

Teile ohne Parts No. werden nicht geliefert.

Ref.No.	A d d	N e w	Parts No.	Description	Dest inati on
KDC-X959/Z939,Z738,Z838W					
200	1A		A02-2712-13	PLASTIC CABINET ASSY	
202	1B		A52-0811-12	TOP PLATE	
203	2A		A21-4175-04	DRESSING PANEL	
204	2A		A21-4209-02	DRESSING PANEL	E1,M1,E2
204	2A	*	A21-4213-02	DRESSING PANEL	K1
205	3A	*	A22-2946-22	SUB PANEL ASSY	
207	1B		A46-1756-11	REAR COVER	
PA1	2A	*	A64-2687-11	PANEL ASSY	K1
PA1	2A	*	A64-2688-11	PANEL ASSY	M1
PA1	2A	*	A64-2689-11	PANEL ASSY	E1
PA1	2A	*	A64-2723-11	PANEL ASSY	E2
RC1	1A		A70-2025-05	REMOTE CONTROLLER ASSY (RC-410)	K1
RC2	1A		A70-2026-05	REMOTE CONTROLLER ASSY (RC-420)	E1,M1,E2
213	1A		B07-3050-02	ESCUTCHEON	E1,M1,E2
213	1A		B07-3057-02	ESCUTCHEON	K1
214	2A	*	B10-4240-01	FRONT GLASS	K1
214	2A	*	B10-4241-01	FRONT GLASS	M1
214	2A	*	B10-4242-01	FRONT GLASS	E1
214	2A	*	B10-4252-01	FRONT GLASS	E2
215	2A		B10-4217-04	FRONT GLASS	
-			B46-0100-50	WARRANTY CARD	
-			B46-0606-04	ID CARD	K1
-			B46-0612-14	ID CARD	E1,M1,E2
-			B46-0645-03	USER CARD	K1
-			B46-0648-03	USER CARD	K1
-			B58-1365-04	CAUTION CARD	
-		*	B64-2257-00	INST. MANUAL (ENGLISH)	K1
-		*	B64-2258-00	INST. MANUAL (FRE,SPA)	K1
-		*	B64-2259-00	INST. MANUAL (ENGLISH)	E1,E2
-		*	B64-2260-00	INST. MANUAL (FRE,GER)	E1,E2
-		*	B64-2261-00	INST. MANUAL (DUT,ITA)	E1,E2
-		*	B64-2262-00	INST. MANUAL (SPA,POR)	E1,E2
-		*	B64-2263-00	INST. MANUAL (ENG,T-CHI)	M1
220	1A		D10-4674-04	LEVER	
221	3A		D10-4675-04	LEVER	
222	3A		D10-4676-04	LEVER	
223	3A		D10-4677-04	LEVER	
224	3A		D10-4678-03	LEVER	
225	3A		D13-2242-04	GEAR	
226	3A		D21-2406-04	SHAFT	
227	3A		D21-2407-04	SHAFT	
229	3A		D39-0237-05	DAMPER	
232	2B		E30-6064-05	CORD WITH PINPLUG (6P)	K1,E1,M1
232	2B		E30-6066-05	CORD WITH PINPLUG (4P)	E2
233	2B	*	E30-6067-15	CORD WITH PINPLUG (AUX 2P)	K1,M1
234	2B		E30-6068-05	CORD WITH DIN CONNECTOR (13P)	
235	2B		E30-6069-05	CORD WITH DIN CONNECTOR (4P)	E1,E2
DC1	1A		E30-6062-05	DC CORD	K1
DC2	1A		E30-6063-05	DC CORD	E1,M1,E2
FC1	2B		E39-0447-05	FLAT CABLE (24P)	
245	2B		F29-0049-05	INSULATING COVER	
F1	2B		F52-0006-05	FUSE (MINI BLADE TYPE) (10A)	

Ref.No.	A d d	N e w	Parts No.	Description	Dest inati on
F1	2B		F52-0011-05	FUSE (MINI BLADE TYPE) (10A)	
250	2A		G01-3135-04	COMPRESSION SPRING	
251	3A		G01-3136-14	EXTENSION SPRING	
252	3A		G02-1428-04	FLAT SPRING	
253	3B		G02-1429-04	FLAT SPRING	
-		*	H10-4802-12	POLYSTYRENE FOAMED FIXTURE	
-		*	H11-1538-04	POLYSTYRENE FOAMED BOARD	
-			H25-0329-04	PROTECTION BAG (280X450X0.03)	K1,M1
-			H25-0337-04	PROTECTION BAG (180X300X0.03)	
-			H25-1111-04	PROTECTION BAG (280X450X0.03)	E1,E2
-		*	H54-2392-03	ITEM CARTON CASE	K1
-		*	H54-2393-03	ITEM CARTON CASE	M1
-		*	H54-2394-03	ITEM CARTON CASE	E1
-		*	H54-2511-03	ITEM CARTON CASE	E2
260	1B		J21-9823-03	MOUNTING HARDWARE ASSY	
261	3A		J21-9831-04	MOUNTING HARDWARE ASSY	
268	2A		K24-3837-04	KNOB (OPEN)	
270	2A		K24-3850-04	KNOB (SKIP UP)	E1,M1,E2
270	2A		K24-3852-04	KNOB (SKIP UP)	K1
271	2A		K24-3851-04	KNOB (SKIP DOWN)	E1,M1,E2
271	2A		K24-3853-04	KNOB (SKIP DOWN)	K1
272	2A	*	K25-1417-13	KNOB (EQ, SRC)	
273	2A		K25-1418-03	KNOB (PAUSE)	
274	2A		K25-1423-03	KNOB (VOL)	
275	2A		K25-1428-03	KNOB (PRE1-3, ATT, Q)	K1
275	2A		K25-1456-03	KNOB (PRE1-3)	E1,M1,E2
276	2A		K25-1420-03	KNOB (PRE4-6, TI, DISP)	E1,M1,E2
276	2A		K25-1429-03	KNOB (PRE4-6, AUTO, DISP)	K1
277	2A	*	K25-1458-13	KNOB (FM, AM)	
280	1A		N99-1656-05	SCREW SET	
281	1A		N99-1723-05	SCREW SET	K1,M1
A	1B		N09-6006-05	TAPTITE SCREW (PAN ST 2X3.5T)	
B	3A		N09-6053-05	MACHINE SCREW (M2.6X5)	
C	3A		N19-2168-05	FLAT WASHER	
D	3A		N24-3020-46	E TYPE RETAINING RING (2X5X1.7)	
E	3A		N30-2003-46	PAN HEAD MACHINE SCREW	
F	1B		N30-3006-45	PAN HEAD MACHINE SCREW	
G	3B		N30-3010-46	PAN HEAD MACHINE SCREW	
H	2A		N80-2006-46	PAN HEAD TAPTITE SCREW	
J	1A		N80-2008-45	PAN HEAD TAPTITE SCREW	
K	1B		N83-3005-46	PAN HEAD TAPTITE SCREW	
L	3A		N84-2606-46	PAN HEAD TAPTITE SCREW	
282	1A		T90-0523-05	ANTENNA ADAPTOR	E1,M1,E2
282	1A		T90-0534-05	ANTENNA ADAPTOR	E1,M1,E2
282	1A		T90-0552-05	ANTENNA ADAPTOR	E1,M1,E2
DME1	1B		X92-4450-01	MECHANISM ASSY (DXM-6111W)	E2
DME1	1B	*	X92-4590-01	MECHANISM ASSY (DXM-6511W)	K1,E1,M1
SWITCH UNIT (X16-169X-XX)					
C3-5			CK73GB1C104K	CHIP C 0.10UF	K
C6			CK73FB1A225K	CHIP C 2.2UF	K
C7			CC73GCH1H101J	CHIP C 100PF	J
C8			CK73EB0J106K	CHIP C 10UF	K

K1 : KDC-X959 M1 : KDC-Z939 E1 : Z838W E2 : Z738

⚠ indicates safety critical components.

KDC-X959/Z939,Z738,Z838W

PARTS LIST

* New Parts

Parts without Parts No. are not supplied.

Les articles non mentionnes dans le Parts No. ne sont pas fournis.

Teile ohne Parts No. werden nicht geliefert.

SWITCH UNIT (X16-169X-XX)

Ref.No.	A d d	N e w	Parts No.	Description	Dest inati on
C9			CK73FB1A225K	CHIP C 2.2UF K	K1,M1,E1
C10			CK73GB0J105K	CHIP C 1.0UF K	
C11			CK73GB1C104K	CHIP C 0.10UF K	
C16-19			CK73GB1H103K	CHIP C 0.010UF K	
C20,21			CK73GB1C104K	CHIP C 0.10UF K	
C22,23		*	C92-1736-05	CHIP-TAN 2.2UF 35WV	
C24-35			CK73GB1C104K	CHIP C 0.10UF K	
C36			C92-0628-05	CHIP-TAN 10UF 10WV	
C37			CK73GB1H104K	CHIP C 0.10UF K	
CN1			E40-5848-05	FLAT CABLE CONNECTOR (30P)	
FC2	2A	*	E39-0449-05	FLAT CABLE (30P)	
J1			E59-0829-05	RECTANGULAR PLUG (16P)	
L1,2			L92-0332-05	CHIP FERRITE	
X1		*	L78-0868-05	RESONATOR (5.00MHZ)	K1,M1,E1
CP3		*	R90-1503-05	MULTI-COMP 47K X4	
CP4		*	R90-0723-05	MULTI-COMP 47K X2	
CP5		*	R90-1085-05	MULTI-COMP 22K X4	
CP6		*	R90-1524-05	MULTI-COMP 220 X4	
CP7-15		*	R90-1085-05	MULTI-COMP 22K X4	
CP16		*	R90-1096-05	MULTI-COMP 10K X4	
CP17		*	R90-1502-05	MULTI-COMP 470 X4	
CP18		*	R90-1094-05	MULTI-COMP 1K X4	
CP19		*	R90-1524-05	MULTI-COMP 220 X4	
CP20		*	R90-1502-05	MULTI-COMP 470 X4	
CP21,22		*	R90-1524-05	MULTI-COMP 220 X4	
CP23-28		*	R90-1502-05	MULTI-COMP 470 X4	
CP29			R90-0737-05	MULTI-COMP 100K X2	
CP30			R90-1020-05	MULTI-COMP 22K X2	
CP32			R90-1022-05	MULTI-COMP 470 X2	
CP33		*	R90-1502-05	MULTI-COMP 470 X4	
CP34		*	R90-1094-05	MULTI-COMP 1K X4	
CP35			R90-0726-05	MULTI-COMP 10K X2	
CP37		*	R90-1504-05	MULTI-COMP 100K X4	
CP38		*	R90-1085-05	MULTI-COMP 22K X4	
CP39			R90-1022-05	MULTI-COMP 470 X2	
CP40		*	R90-1085-05	MULTI-COMP 22K X4	
CP41-44		*	R90-1524-05	MULTI-COMP 220 X4	
R1			RK73GB2A682J	CHIP R 6.8K J 1/10W	K1,M1,E1
R2			RK73GB2A183J	CHIP R 18K J 1/10W	
R3			RK73EB2E222J	CHIP R 2.2K J 1/4W	
R10			RK73GB2A102J	CHIP R 1.0K J 1/10W	
R11			RK73GB2A101J	CHIP R 100 J 1/10W	
R12			RK73GB2A104J	CHIP R 100K J 1/10W	
R13,14			RK73GB2A274J	CHIP R 270K J 1/10W	
R15,16			RK73GB2A153J	CHIP R 15K J 1/10W	
R17			RK73GB2A104J	CHIP R 100K J 1/10W	
R48-50			RK73FB2B471J	CHIP R 470 J 1/8W	
R51-53			RK73FB2B471J	CHIP R 470 J 1/8W	
R56,57			RK73EB2E681J	CHIP R 680 J 1/4W	
R58			RK73GB2A102J	CHIP R 1.0K J 1/10W	M1,E1,E2
R59			RK73GB2A103J	CHIP R 10K J 1/10W	
R60			RK73GB2A223J	CHIP R 22K J 1/10W	
R61			RK73GB2A471J	CHIP R 470 J 1/10W	
R64,65			RK73GB2A102J	CHIP R 1.0K J 1/10W	

Ref.No.	A d d	N e w	Parts No.	Description	Dest inati on	
R66			RK73GB2A223J	CHIP R 22K J 1/10W	E2	
R67			RK73GB2A333J	CHIP R 33K J 1/10W		
R69,70			RK73GB2A471J	CHIP R 470 J 1/10W		
R71			RK73GB2A223J	CHIP R 22K J 1/10W		
R72			RK73GB2A103J	CHIP R 10K J 1/10W		
R73			RK73GB2A104J	CHIP R 100K J 1/10W		
R74			RK73GB2A471J	CHIP R 470 J 1/10W		
R75			RK73GB2A101J	CHIP R 100 J 1/10W		
R76			RK73GB2A471J	CHIP R 470 J 1/10W		
R79-82			RK73GB2A471J	CHIP R 470 J 1/10W		
S1			S70-0863-05	TACT SWITCH	M1,E1,E2	
S2,3			S70-0856-05	TACT SWITCH		
S2,3			S70-0873-05	TACT SWITCH		
S4			S70-0857-05	TACT SWITCH		
S5-10			S70-0856-05	TACT SWITCH		
S5-10			S70-0873-05	TACT SWITCH	K1	
S11			S70-0857-05	TACT SWITCH		
S12,13			S70-0856-05	TACT SWITCH	M1,E1,E2	
S12,13			S70-0873-05	TACT SWITCH		
S14			S70-0857-05	TACT SWITCH		
S15-19			S70-0856-05	TACT SWITCH	M1,E1,E2	
S15-19			S70-0873-05	TACT SWITCH		
S20			S70-0857-05	TACT SWITCH		
D2,3			FT26.8E	ZENER DIODE	K1,M1,E1	
D6			MA8068-M	ZENER DIODE		
D7			DA204U	DIODE		
D11			1SR154-400	DIODE		
D12			DAN202K	DIODE		
IC1		*	SI-3033LSA-TL	ANALOGUE IC		
IC2			TC74HC4050AFT	MOS-IC		
IC3			RS-171	ANALOGUE IC		
IC4			BA3830F	ANALOGUE IC		
IC5		*	M25P20	ROM IC		
IC6		*	MX23L3213T1109	MEMORY IC	K1,M1,E1	
IC7		*	IS61LV641615TI	SRAM IC		
IC8		*	703107AGJ121	MI-COM IC		
IC9			TC7WT126FU	MOS-IC		
IC10			TC7SH08F	MOS-IC		
Q4			DTC123JUA	DIGITAL TRANSISTOR		M1,E1,E2
Q5			DTC123JUA	DIGITAL TRANSISTOR		
Q6			CPH3105	TRANSISTOR		
Q8			DTC114EUA	DIGITAL TRANSISTOR		
Q8			UN5111	DIGITAL TRANSISTOR		
Q9			DTC123JUA	DIGITAL TRANSISTOR		
ED1	2A	*	W02-3324-05	ELECTRIC CIRCUIT MODULE		
ELECTRIC UNIT (X25-927X-XX)						
D101			B30-1566-05	LED (1608,RED)		
C1			C90-5377-05	ELECTRO 3900UF 16WV		
C2			CK73GB1H103K	CHIP C 0.010UF K		
C3			CK73GB1C104K	CHIP C 0.10UF K		
C4			CE04NW1A101M	ELECTRO 100UF 10WV		
C4			C90-5442-05	ELECTRO 100UF 10WV		

K1 : KDC-X959 M1 : KDC-Z939 E1 : Z838W E2 : Z738

⚠ indicates safety critical components.

KDC-X959/Z939,Z738,Z838W

PARTS LIST

* New Parts

Parts without Parts No. are not supplied.

Les articles non mentionnes dans le Parts No. ne sont pas fournis.

Teile ohne Parts No. werden nicht geliefert.

ELECTRIC UNIT (X25-927X-XX)

Ref.No.	A d d	N e w	Parts No.	Description	Dest inati on
C5,6			CE04NW1E4R7M	ELECTRO 4.7UF 25WV	K1,M1
C7			CK73FB1C105K	CHIP C 1.0UF K	
C8			CE04DW1A221M	ELECTRO 220UF 10WV	
C9			CK73FB1C224K	CHIP C 0.22UF K	
C10			CK73GB1H103K	CHIP C 0.010UF K	
C11			C90-2966-05	ELECTRO 100UF 16WV	
C12			CK73GB1H103K	CHIP C 0.010UF K	
C13			C90-2966-05	ELECTRO 100UF 16WV	
C16			CK73GB1C104K	CHIP C 0.10UF K	
C19			CK73GB1H103K	CHIP C 0.010UF K	
C20			CK73GB1H103K	CHIP C 0.010UF K	M1,E1,E2
C21			CK73GB1E223K	CHIP C 0.022UF K	
C22			C90-2558-05	ELECTRO 1.0UF 50WV	K1,M1,E1
C23			CE04NW1E4R7M	ELECTRO 4.7UF 25WV	
C24			C90-2966-05	ELECTRO 100UF 16WV	
C25-28			CK73EB1C225K	CHIP C 2.2UF K	
C29			CE04NW1C220M	ELECTRO 22UF 16WV	K1,M1,E1
C30			CK73GB1E223K	CHIP C 0.022UF K	
C31			CK73GB1H103K	CHIP C 0.010UF K	K1,M1,E1
C32,33			CE04NW1E4R7M	ELECTRO 4.7UF 25WV	
C34			C90-2556-05	ELECTRO 3.3UF 50WV	
C35			CK73GB1C683K	CHIP C 0.068UF K	
C36			C90-2562-05	ELECTRO 0.10UF 50WV	
C37			CK73GB1H102K	CHIP C 1000PF K	
C38,39			CK73GB1H103K	CHIP C 0.010UF K	
C40,41			CK73GB1H103K	CHIP C 0.010UF K	K1,M1
C42			CC73GCH1H270J	CHIP C 27PF J	
C43			CC73GCH1H220J	CHIP C 22PF J	K1,M1
C44			CE04NW1A220M	ELECTRO 22UF 10WV	
C45			CE04NW1C100M	ELECTRO 10UF 16WV	
C46,47			C90-2658-05	NP-ELEC 1.0UF 50WV	K1,M1
C48			CK73GB1H103K	CHIP C 0.010UF K	
C49-53			CE04NW1E4R7M	ELECTRO 4.7UF 25WV	
C49-53			C90-5444-05	ELECTRO 4.7UF 25WV	
C54			CK73GB1H103K	CHIP C 0.010UF K	
C55			CK73FB1C105K	CHIP C 1.0UF K	K1,M1
C56,57			C90-2524-05	NP-ELEC 4.7UF 16WV	
C58			CE04NW1C100M	ELECTRO 10UF 16WV	
C59			CE04MW1C100M	ELECTRO 10UF 16WV	
C60			CE04NW1H2R2M	ELECTRO 2.2UF 50WV	
C63			CE04NW1E4R7MEL	ELECTRO 4.7UF 25WV	
C65,66		*	C90-2658-05	NP-ELEC 1.0UF 50WV	K1,M1,E1
C67,68			CE04NW1HR47M	ELECTRO 0.47UF 50WV	
C69			CE04NW0J470M	ELECTRO 47UF 6.3WV	
C70			CK73GB1A474K	CHIP C 0.47UF K	
C71			CC73GCH1H151J	CHIP C 150PF J	
C72			CK73GB1E333K	CHIP C 0.033UF K	K1,M1,E1
C73			CK73GB1H103K	CHIP C 0.010UF K	
C74,75			CK73GB1C104K	CHIP C 0.10UF K	
C76-79			C90-2524-05	NP-ELEC 4.7UF 16WV	
C81,82			C90-5429-05	NP-ELEC 0.33UF 50WV	
C83,84			CK73FB1C334K	CHIP C 0.33UF K	K1,M1,E1
C85,86			CE04NW1HR33M	ELECTRO 0.33UF 50WV	
C87,88			CK73FB1C334K	CHIP C 0.33UF K	
C89-92			CK73GB1C104K	CHIP C 0.10UF K	

Ref.No.	A d d	N e w	Parts No.	Description	Dest inati on
C93,94			CE04NW1C100M	ELECTRO 10UF 16WV	E2
C93,94			CE04NW1C220M	ELECTRO 22UF 16WV	
C95,96			CE04NW1C100M	ELECTRO 10UF 16WV	K1,M1,E1
C97,98			CK73GB1H222K	CHIP C 2200PF K	
C99,100			CE04NW1C100M	ELECTRO 10UF 16WV	E2
C99,100			CE04NW1C220M	ELECTRO 22UF 16WV	K1,M1,E1
C101,102			CE04NW1C100M	ELECTRO 10UF 16WV	
C103,104			CK73GB1H222K	CHIP C 2200PF K	K1,M1,E1
C105,106			CE04NW1C220M	ELECTRO 22UF 16WV	
C107,108			CE04NW1C100M	ELECTRO 10UF 16WV	K1,M1,E1
C109,110			CK73GB1H222K	CHIP C 2200PF K	K1,M1,E1
C111			CK73GB1H102K	CHIP C 1000PF K	
C113			CE04NW1C470M	ELECTRO 47UF 16WV	K1,M1,E1
C114			C90-2551-05	ELECTRO 33UF 10WV	
C115,116			C90-2558-05	ELECTRO 1.0UF 50WV	
C117-120			C90-5297-05	NP-ELECT 0.22UF 50WV	M1,E1,E2
C121			CK73GB1H103K	CHIP C 0.010UF K	
C129			C90-5308-05	ELECTRO 1.0UF 50WV	K1,M1,E1
C130			CK73FB1C334K	CHIP C 0.33UF K	
C131			CK73GB1H103K	CHIP C 0.010UF K	
C132			CC73GCH1H100D	CHIP C 10PF D	
C133			CK73GB1H103K	CHIP C 0.010UF K	
C134			CC73GCH1H100D	CHIP C 10PF D	
C135			CK73GB1H103K	CHIP C 0.010UF K	
C136			CC73GCH1H100D	CHIP C 10PF D	
C137			CK73GB1H103K	CHIP C 0.010UF K	K1,M1
C139			CK73GB1H103K	CHIP C 0.010UF K	
C141			CK73GB1H331K	CHIP C 330PF K	K1,M1
C142,143			C90-2597-05	ELECTRO 10UF 16WV	
C142,143			C90-5437-05	ELECTRO 10UF 16WV	
C144			CK73GB1H103K	CHIP C 0.010UF K	K1,M1
C145,146			CC73GCH1H100D	CHIP C 10PF D	
C201,202			CK73GB1H332K	CHIP C 3300PF K	
C203			CK73GB1H104K	CHIP C 0.10UF K	
C204			CK73GB1H103K	CHIP C 0.010UF K	
C205			CK73GB1H104K	CHIP C 0.10UF K	K1,M1
C206			CK73GB1C104K	CHIP C 0.10UF K	
C305			CK73FB0J475K	CHIP C 4.7UF K	K1,M1,E1
C351			CK73GB1H102K	CHIP C 1000PF K	
C352			CE04NW1C470M	ELECTRO 47UF 16WV	
C352			C90-5443-05	ELECTRO 47UF 16WV	
C353			CK73GB1H103K	CHIP C 0.010UF K	
C354			CK73FB1C105K	CHIP C 1.0UF K	K1,M1,E1
C355			CK73GB1C104K	CHIP C 0.10UF K	
C473			C90-2965-05	ELECTRO 220UF 10WV	
C474,475			C90-2963-05	ELECTRO 100UF 25WV	K1,M1,E1
C479			C90-2547-05	ELECTRO 100UF 6.3WV	
C480			C90-2554-05	ELECTRO 10UF 16WV	E2
C481			CK73GB1H103K	CHIP C 0.010UF K	
C484			CK73GB1H103K	CHIP C 0.010UF K	
C485			C90-2980-05	ELECTRO 220UF 16WV	K1,M1,E1
C702			CE04NW1C100M	ELECTRO 10UF 16WV	
C703			CK73GB1H103K	CHIP C 0.010UF K	K1,M1,E1
C704			CE04NW0J470M	ELECTRO 47UF 6.3WV	
C802			CK73FB1H104K	CHIP C 0.10UF K	

K1 : KDC-X959 M1 : KDC-Z939 E1 : Z838W E2 : Z738

▲ indicates safety critical components.

PARTS LIST

* New Parts

Parts without Parts No. are not supplied.

Les articles non mentionnes dans le Parts No. ne sont pas fournis.

Teile ohne Parts No. werden nicht geliefert.

ELECTRIC UNIT (X25-927X-XX)

Ref.No.	A d d	N e w	Parts No.	Description	Dest inati on	Ref.No.	A d d	N e w	Parts No.	Description	Dest inati on
C803,804			CK73FB1H104K	CHIP C 0.10UF K		CP15			R90-1054-05	MULTI-COMP 2.2K X4	
C849			C90-2954-05	ELECTRO 3.3UF 25WV		CP16			R90-1058-05	MULTI-COMP 100K X4	
C850			CK73EB1E105K	CHIP C 1.0UF K		CP17			R90-1046-05	MULTI-COMP 1K X2	
C852			CK73GB1H103K	CHIP C 0.010UF K	E1,E2	R1			RK73GB2A104J	CHIP R 100K J 1/10W	
C853			CK73GB1C104K	CHIP C 0.10UF K		R2			RK73FB2B152J	CHIP R 1.5K J 1/8W	
C855			CK73GB1H103K	CHIP C 0.010UF K	E1,E2	R3			RK73GB2A223J	CHIP R 22K J 1/10W	
C856			CK73GB1H103K	CHIP C 0.010UF K		R4			RK73GB2A222J	CHIP R 2.2K J 1/10W	
C858,859			CK73GB1H103K	CHIP C 0.010UF K		R5			RK73EB2E221J	CHIP R 220 J 1/4W	
C860,861			CK73GB1H104K	CHIP C 0.10UF K		R6			RK73GB2A153J	CHIP R 15K J 1/10W	
C863			CK73GB1H103K	CHIP C 0.010UF K		R7			RK73GH1J432D	CHIP R 4.3K D 1/16W	
C864			CK73FB1A225K	CHIP C 2.2UF K		R8			RK73GH1J243D	CHIP R 24K D 1/16W	
C900			CK73GB1H103K	CHIP C 0.010UF K		R10			RK73GB2A562J	CHIP R 5.6K J 1/10W	
C902			CK73GB1C104K	CHIP C 0.10UF K		R11			RK73GB2A104J	CHIP R 100K J 1/10W	
C903			CC73GCH1H151J	CHIP C 150PF J		R13			RK73EB2E102J	CHIP R 1.0K J 1/4W	
C904			CK73GB1H104K	CHIP C 0.10UF K		R14			RK73FB2B561J	CHIP R 560 J 1/8W	
CN1			E41-0174-05	PIN ASSY (10P)		R15			RK73EB2E103J	CHIP R 10K J 1/4W	M1,E1,E2
CN2			E40-3299-05	PIN ASSY (2P)		R16			RK73GB2A104J	CHIP R 100K J 1/10W	K1
CN3			E40-3266-05	PIN ASSY (8P)		R16			RK73GB2A223J	CHIP R 22K J 1/10W	M1,E1,E2
CN4			E40-3261-05	PIN ASSY (3P)		R17			RK73GB2A473J	CHIP R 47K J 1/10W	M1,E1,E2
CN6			E40-9490-15	PIN ASSY (20P)		R18			RK73EB2E471J	CHIP R 470 J 1/4W	
CN7			E40-3261-05	PIN ASSY (3P)	K1,M1	R19			RK73EB2E103J	CHIP R 10K J 1/4W	
CN8			E41-0194-05	FLAT CABLE CONNECTOR (24P)		R20			RK73GB2A104J	CHIP R 100K J 1/10W	
CN9			E40-3263-05	PIN ASSY (5P)	E1,E2	R21			RK73FB2B102J	CHIP R 1.0K J 1/8W	K1,M1,E1
J1			E58-0863-15	RECTANGULAR RECEPTACLE (16P)		R23			RK73GB2A750J	CHIP R 75 J 1/10W	K1,M1,E1
W9	2B		E30-6098-05	CORD WITH PLUG		R24			RK73GB2A272J	CHIP R 2.7K J 1/10W	K1,M1,E1
L1			L33-1170-05	CHOKE COIL ASSY (140UH)		R25			RK73GB2A470J	CHIP R 47 J 1/10W	K1,M1,E1
L2			L33-1153-05	SMALL FIXED INDUCTOR (10UH)		R26			RK73GB2A752J	CHIP R 7.5K J 1/10W	K1,M1,E1
L3			L40-2201-78	SMALL FIXED INDUCTOR (22UH)	K1,M1,E1	R27			RK73GB2A563J	CHIP R 56K J 1/10W	K1,M1,E1
L5			L40-4792-78	SMALL FIXED INDUCTOR (4.7UH)		R28			RK73GB2A913J	CHIP R 91K J 1/10W	K1,M1,E1
L7			L33-1039-05	LINE FILTER COIL (52mH)		R29			RK73GB2A470J	CHIP R 47 J 1/10W	K1,M1,E1
L9-14			L40-4795-68	SMALL FIXED INDUCTOR (4.7UH)		R30			RK73GB2A103J	CHIP R 10K J 1/10W	K1,M1,E1
L351			L92-0075-05	CHIP FERRITE		R31,32			RK73GB2A913J	CHIP R 91K J 1/10W	K1,M1,E1
L352			L40-4792-78	SMALL FIXED INDUCTOR (4.7UH)		R33			RK73GB2A472J	CHIP R 4.7K J 1/10W	
L471			L33-1853-05	CHOKE COIL (100UH)	K1,M1,E1	R35			RK73GB2A471J	CHIP R 470 J 1/10W	
L472			L40-4792-78	SMALL FIXED INDUCTOR (4.7UH)		R36			RK73GB2A104J	CHIP R 100K J 1/10W	
L500		*	L33-1866-05	SMALL FIXED INDUCTOR (4.7UH)		R37			RK73FB2B472J	CHIP R 4.7K J 1/8W	
L501			L92-0308-05	FERRITE CORE		R38			R92-0365-05	CHIP R 1.0K J 1/2W	
X1			L78-0821-05	RESONATOR (20.0MHZ)		R39			RK73GB2A223J	CHIP R 22K J 1/10W	
X3			L77-2002-05	CRYSTAL RESONATOR (4.332MHZ)		R40			R92-0365-05	CHIP R 1.0K J 1/2W	
X4			L77-2738-05	CRYSTAL RESONATOR (32.768KHZ)		R41			RK73GB2A123J	CHIP R 12K J 1/10W	
F	2B		N30-3006-45	PAN HEAD MACHINE SCREW		R42			RK73GB2A223J	CHIP R 22K J 1/10W	
G	2A		N30-3010-46	PAN HEAD MACHINE SCREW		R43			RK73GB2A153J	CHIP R 15K J 1/10W	
K	2B		N83-3005-46	PAN HEAD TAPTITE SCREW		R44			RK73GB2A223J	CHIP R 22K J 1/10W	
N	2B		N80-3008-46	PAN HEAD TAPTITE SCREW		R45			RD14DB2H332J	SMALL-RD 3.3K J 1/2W	
CP2			R90-1016-05	MULTI-COMP 470 X4		R46			RK73EB2E473J	CHIP R 47K J 1/4W	
CP3,4			R90-1022-05	MULTI-COMP 470 X2		R47			RK73GB2A183J	CHIP R 18K J 1/10W	
CP5			R90-0725-05	MULTI-COMP 1K X2		R48			RK73GB2A104J	CHIP R 100K J 1/10W	
CP6			R90-1013-05	MULTI-COMP 2.2K X2		R50			RK73GB2A104J	CHIP R 100K J 1/10W	K1,M1
CP7			R90-1048-05	MULTI-COMP 4.7K X2		R52-54			RK73GB2A473J	CHIP R 47K J 1/10W	K1,M1
CP8			R90-1508-05	MULTI-COMP 100 X2		R55,56			RK73EB2E100J	CHIP R 10 J 1/4W	K1,M1
CP9			R90-1048-05	MULTI-COMP 4.7K X2		R57			RK73EB2E4R7J	CHIP R 4.7 J 1/4W	K1,M1
CP10			R90-1045-05	MULTI-COMP 470 X2		R58			RK73GB2A104J	CHIP R 100K J 1/10W	
CP11-13			R90-1051-05	MULTI-COMP 100K X2		R98			RK73GB2A472J	CHIP R 4.7K J 1/10W	
CP14			R90-1509-05	MULTI-COMP 100 X4	E1,E2	R103			RK73FB2B472J	CHIP R 4.7K J 1/8W	
						R111			RK73FB2B223J	CHIP R 22K J 1/8W	K1

K1 : KDC-X959 M1 : KDC-Z939 E1 : Z838W E2 : Z738

△ indicates safety critical components.

KDC-X959/Z939,Z738,Z838W

PARTS LIST

* New Parts

Parts without Parts No. are not supplied.

Les articles non mentionnes dans le Parts No. ne sont pas fournis.

Teile ohne Parts No. werden nicht geliefert.

ELECTRIC UNIT (X25-927X-XX)

Ref.No.	A d d	N e w	Parts No.	Description	Dest inati on
R112			R92-0366-05	CHIP R 560 J 1W	K1
R115			RK73GB2A333J	CHIP R 33K J 1/10W	
R121			RK73EB2E102J	CHIP R 1.0K J 1/4W	E1,E2
R122-124			RK73EB2E471J	CHIP R 470 J 1/4W	E1,E2
R127			RK73GB2A222J	CHIP R 2.2K J 1/10W	
R130,131			RK73EB2E472J	CHIP R 4.7K J 1/4W	
R132-134			RK73EB2E101J	CHIP R 100 J 1/4W	
R135-137			RK73EB2E472J	CHIP R 4.7K J 1/4W	
R140			RK73GB2A473J	CHIP R 47K J 1/10W	
R141			RK73GB2A153J	CHIP R 15K J 1/10W	
R142			RK73GB2A102J	CHIP R 1.0K J 1/10W	
R143			RK73GB2A473J	CHIP R 47K J 1/10W	
R144			RK73GB2A333J	CHIP R 33K J 1/10W	
R145			RK73GB2A473J	CHIP R 47K J 1/10W	
R146			RK73GB2A821J	CHIP R 820 J 1/10W	
R147			RK73FB2B102J	CHIP R 1.0K J 1/8W	
R148			RK73FB2B912J	CHIP R 9.1K J 1/8W	
R149			RK73FB2B243J	CHIP R 24K J 1/8W	
R150			RK73GB2A472J	CHIP R 4.7K J 1/10W	
R151			RK73GB2A103J	CHIP R 10K J 1/10W	
R152			RK73GB2A472J	CHIP R 4.7K J 1/10W	
R153,154			RK73GB2A334J	CHIP R 330K J 1/10W	
R155,156			RK73EB2E100J	CHIP R 10 J 1/4W	
R157			RK73EB2E4R7J	CHIP R 4.7 J 1/4W	
R161,162			RK73FB2B471J	CHIP R 470 J 1/8W	
R163,164			RK73FB2B222J	CHIP R 2.2K J 1/8W	K1,M1,E1
R163,164			RK73FB2B223J	CHIP R 22K J 1/8W	E2
R165,166			RK73FB2B103J	CHIP R 10K J 1/8W	K1,M1,E1
R167,168			RK73FB2B223J	CHIP R 22K J 1/8W	K1,M1,E1
R169,170			RK73FB2B820J	CHIP R 82 J 1/8W	K1,M1,E1
R171,172			RK73FB2B471J	CHIP R 470 J 1/8W	
R173,174			RK73FB2B222J	CHIP R 2.2K J 1/8W	K1,M1,E1
R173,174			RK73FB2B223J	CHIP R 22K J 1/8W	E2
R175,176			RK73FB2B103J	CHIP R 10K J 1/8W	K1,M1,E1
R177,178			RK73FB2B223J	CHIP R 22K J 1/8W	K1,M1,E1
R179,180			RK73FB2B820J	CHIP R 82 J 1/8W	
R181,182			RK73FB2B471J	CHIP R 470 J 1/8W	K1,M1,E1
R183,184			RK73FB2B222J	CHIP R 2.2K J 1/8W	K1,M1,E1
R185,186			RK73FB2B103J	CHIP R 10K J 1/8W	K1,M1,E1
R187,188			RK73FB2B223J	CHIP R 22K J 1/8W	K1,M1,E1
R189,190			RK73FB2B820J	CHIP R 82 J 1/8W	K1,M1,E1
R200			RK73GB2A221J	CHIP R 220 J 1/10W	
R201			RK73GB2A102J	CHIP R 1.0K J 1/10W	
R202			RK73GB2A103J	CHIP R 10K J 1/10W	
R203			RK73GB2A432J	CHIP R 4.3K J 1/10W	
R204			RK73GB2A100J	CHIP R 10 J 1/10W	
R205			RK73GB2A222J	CHIP R 2.2K J 1/10W	E2
R206,207			RK73GB2A104J	CHIP R 100K J 1/10W	E2
R210			RK73FB2B102J	CHIP R 1.0K J 1/8W	
R211			RK73GB2A223J	CHIP R 22K J 1/10W	
R212			RK73FB2B102J	CHIP R 1.0K J 1/8W	
R213			RK73GB2A223J	CHIP R 22K J 1/10W	
R230			RK73GB2A222J	CHIP R 2.2K J 1/10W	
R231			RK73GB2A103J	CHIP R 10K J 1/10W	
R242			RK73GB2A472J	CHIP R 4.7K J 1/10W	

Ref.No.	A d d	N e w	Parts No.	Description	Dest inati on
R301			RK73GB2A104J	CHIP R 100K J 1/10W	
R303			RK73GB2A241J	CHIP R 240 J 1/10W	
R305			RK73GB2A394J	CHIP R 390K J 1/10W	
R306			RK73GB2A101J	CHIP R 100 J 1/10W	
R353			RK73GB2A102J	CHIP R 1.0K J 1/10W	
R355			RK73GB2A102J	CHIP R 1.0K J 1/10W	
R357			RK73GB2A222J	CHIP R 2.2K J 1/10W	
R358			RK73GB2A102J	CHIP R 1.0K J 1/10W	
R359			RK73GB2A104J	CHIP R 100K J 1/10W	
R360			RK73GB2A471J	CHIP R 470 J 1/10W	
R361,362			RK73GB2A222J	CHIP R 2.2K J 1/10W	
R364			RK73GB2A104J	CHIP R 100K J 1/10W	
R366			RK73GB2A102J	CHIP R 1.0K J 1/10W	
R367			RK73GB2A473J	CHIP R 47K J 1/10W	
R370			RK73GB2A104J	CHIP R 100K J 1/10W	
R375			RK73GB2A105J	CHIP R 1.0M J 1/10W	
R382			RK73GB2A104J	CHIP R 100K J 1/10W	K1,M1
R382			RK73GB2A225J	CHIP R 2.2M J 1/10W	E1,E2
R384			RK73GB2A222J	CHIP R 2.2K J 1/10W	E1,E2
R389			RK73GB2A102J	CHIP R 1.0K J 1/10W	
R390			RK73GB2A473J	CHIP R 47K J 1/10W	
R392			RK73GB2A473J	CHIP R 47K J 1/10W	K1,M1,E1
R393			RK73GB2A104J	CHIP R 100K J 1/10W	
R397			RK73GB2A102J	CHIP R 1.0K J 1/10W	
R400			RK73GB2A101J	CHIP R 100 J 1/10W	
R401			RK73GB2A102J	CHIP R 1.0K J 1/10W	
R402			RK73GB2A471J	CHIP R 470 J 1/10W	K1,M1
R403			RK73GB2A104J	CHIP R 100K J 1/10W	K1,M1
R404			RK73GB2A104J	CHIP R 100K J 1/10W	E1,E2
R405			RK73GB2A104J	CHIP R 100K J 1/10W	M1,E1,E2
R406			RK73GB2A104J	CHIP R 100K J 1/10W	K1
R407			RK73GB2A104J	CHIP R 100K J 1/10W	E2
R408			RK73GB2A104J	CHIP R 100K J 1/10W	K1,M1,E1
R410			RK73GB2A104J	CHIP R 100K J 1/10W	
R412			RK73GB2A104J	CHIP R 100K J 1/10W	
R414			RK73GB2A104J	CHIP R 100K J 1/10W	
R417			RK73GB2A223J	CHIP R 22K J 1/10W	
R421			RK73GB2A473J	CHIP R 47K J 1/10W	
R422			RK73GB2A223J	CHIP R 22K J 1/10W	
R472			RK73GH1J151D	CHIP R 150 D 1/16W	K1,M1,E1
R473			RK73GH1J121D	CHIP R 120 D 1/16W	K1,M1,E1
R474			RK73GH1J681D	CHIP R 680 D 1/16W	K1,M1,E1
R475			RK73FB2B223J	CHIP R 22K J 1/8W	
R476			RK73FB2B223J	CHIP R 22K J 1/8W	E2
R477			RK73GB2A102J	CHIP R 1.0K J 1/10W	K1,M1,E1
R702			RK73FB2B223J	CHIP R 22K J 1/8W	
R800			RK73GB2A124J	CHIP R 120K J 1/10W	
R803			RK73GB2A104J	CHIP R 100K J 1/10W	
R815			RK73GB2A222J	CHIP R 2.2K J 1/10W	
R850			RK73GH1J154D	CHIP R 150K D 1/16W	
R851			RK73GH1J123D	CHIP R 12K D 1/16W	
R901			RK73GB2A4R7J	CHIP R 4.7 J 1/10W	
R902			RK73GB2A104J	CHIP R 100K J 1/10W	
R903			RK73GB2A471J	CHIP R 470 J 1/10W	
R905			RK73GB2A471J	CHIP R 470 J 1/10W	

K1 : KDC-X959 **M1** : KDC-Z939 **E1** : Z838W **E2** : Z738

 indicates safety critical components.

PARTS LIST

* New Parts

Parts without Parts No. are not supplied.

Les articles non mentionnes dans le Parts No. ne sont pas fournis.

Teile ohne Parts No. werden nicht geliefert.

ELECTRIC UNIT (X25-927X-XX)

Ref.No.	A d d	N e w	Parts No.	Description	Dest inati on
W7,8			R92-1252-05	CHIP R 0 OHM J 1/16W	E1,E2
W11,12			R92-1252-05	CHIP R 0 OHM J 1/16W	
W14			R92-1252-05	CHIP R 0 OHM J 1/16W	K1,M1,E1
W15-18			R92-1252-05	CHIP R 0 OHM J 1/16W	E2
W111			R92-1252-05	CHIP R 0 OHM J 1/16W	M1,E1,E2
W112-117			R92-1252-05	CHIP R 0 OHM J 1/16W	
W121			R92-1252-05	CHIP R 0 OHM J 1/16W	
S1			S74-0809-05	MICRO SWITCH	
D1			RM10ZLF	DIODE	
D3			MA8082-L	ZENER DIODE	
D5			MA8100-L	ZENER DIODE	
D7			MA8056-M	ZENER DIODE	
D8			MA8047-M	ZENER DIODE	M1,E1,E2
D9			MA4110(N)-M	ZENER DIODE	K1,M1,E1
D10			MA4056(N)-M	ZENER DIODE	K1,M1,E1
D13,14			S1J	DIODE	
D13,14			1SR154-400	DIODE	
D15			1SS133	DIODE	
D16			MA4068(N)-M	ZENER DIODE	
D17			MA4062(N)-M	ZENER DIODE	
D19,20			DAP202U	DIODE	
D19,20			MA142WA	DIODE	
D21			DA204U	DIODE	
D22-24			MA4062-L	ZENER DIODE	
D25,26			RD6.8M(B2)	ZENER DIODE	
D27,28			MA8068-M	ZENER DIODE	
D29			MA8062-L	ZENER DIODE	
D30			DAP202U	DIODE	
D30			MA142WA	DIODE	
D31			MA4062-L	ZENER DIODE	
D32			DAN202U	DIODE	
D32			MA142WK	DIODE	
D33-36			S1J	DIODE	
D33-36			1SR154-400	DIODE	
D38-41			1SR154-400	DIODE	
D39,40			S1J	DIODE	
D42			DA204U	DIODE	
D43			IMSA-6801	SURGE ABSORBER	
D44			MA8068-M	ZENER DIODE	K1,M1
D45			MA8062-L	ZENER DIODE	K1,M1
D46			MA8068-M	ZENER DIODE	K1,M1
D50			MA4056(N)-M	ZENER DIODE	
D51-53			FTZ6.8E	ZENER DIODE	
D54			DA204U	DIODE	
D111,112			S1J	DIODE	
D111,112			1SR154-400	DIODE	
D121-124			MA4062-L	ZENER DIODE	E1,E2
D472			SS14	DIODE	K1,M1,E1
D473			MA8056-M	ZENER DIODE	
D474			MA8100-L	ZENER DIODE	E2
D475,476			SS14	DIODE	
D702			MA8056-M	ZENER DIODE	
IC1		*	UPD703033GFA14	MI-COM IC	K1,M1,E1

Ref.No.	A d d	N e w	Parts No.	Description	Dest inati on
IC1		*	UPD703033GFA15	MI-COM IC	E2
IC2			TDA7407	ANALOGUE IC	
IC3			M5237ML	IC (VOLTAGE REGULATOR)	
IC4			TDA7560	ANALOGUE IC	
IC5			TDA7401	ANALOGUE IC	
IC6			ICL7660SIBA	ANALOGUE IC	K1,M1,E1
IC7			TC74HC02AF	MOS-IC	
IC8			NJM4565M-TE2	ANALOGUE IC	
IC10-12			NJM4565M-TE2	ANALOGUE IC	K1,M1,E1
IC14			TDA7479D	ANALOGUE IC	
IC16			S-80837ANNP	MOS-IC	
IC20			BA3121F	IC (ISO AMP)	K1,M1
IC21			BA3129F	IC (SWITCH)	K1,M1
IC23			SI-8033JD	ANALOGUE IC	K1,M1,E1
IC24		*	LT1930A	ANALOGUE IC	
IC25			BR24C02F-W	MEMORY IC	
Q1			2SD2375	TRANSISTOR	
Q3			2SA1037K	TRANSISTOR	
Q4			2SA2057	TRANSISTOR	
Q5			DTC144EUA	DIGITAL TRANSISTOR	
Q5			UN5213	DIGITAL TRANSISTOR	
Q6,7			DTA124EUA	DIGITAL TRANSISTOR	
Q6,7			UN5112	DIGITAL TRANSISTOR	
Q8			DTC124EUA	DIGITAL TRANSISTOR	
Q8			UN5212	DIGITAL TRANSISTOR	
Q9			2SB1427	TRANSISTOR	
Q10			2SA2057	TRANSISTOR	
Q11			2SC4081	TRANSISTOR	
Q12			DTC124EUA	DIGITAL TRANSISTOR	
Q12			UN5212	DIGITAL TRANSISTOR	
Q13			DTA124EUA	DIGITAL TRANSISTOR	
Q13			UN5112	DIGITAL TRANSISTOR	
Q14			DTA123JK	DIGITAL TRANSISTOR	
Q14			KRA105S	DIGITAL TRANSISTOR	
Q15			DTC144EUA	DIGITAL TRANSISTOR	
Q15			UN5213	DIGITAL TRANSISTOR	
Q16			2SB1443	TRANSISTOR	K1,M1,E1
Q17			2SC4081	TRANSISTOR	K1,M1,E1
Q18			2SA1576A	TRANSISTOR	K1,M1,E1
Q19			2SC4081	TRANSISTOR	K1,M1,E1
Q20			2SA1576A	TRANSISTOR	K1,M1,E1
Q21,22			2SC4081	TRANSISTOR	K1,M1,E1
Q23			2SA1576A	TRANSISTOR	K1,M1,E1
Q26			2SB1277(Q,R)	TRANSISTOR	
Q27			2SA1576A	TRANSISTOR	
Q28			DTA124EUA	DIGITAL TRANSISTOR	
Q28			UN5112	DIGITAL TRANSISTOR	
Q29			DTC114YUA	DIGITAL TRANSISTOR	
Q29			UN5214	DIGITAL TRANSISTOR	
Q30,31			2SC4081	TRANSISTOR	
Q32,33			DTA124EUA	DIGITAL TRANSISTOR	
Q32,33			UN5112	DIGITAL TRANSISTOR	
Q34			2SC4081	TRANSISTOR	
Q35			DTC124EUA	DIGITAL TRANSISTOR	
Q35			UN5212	DIGITAL TRANSISTOR	

K1 : KDC-X959 M1 : KDC-Z939 E1 : Z838W E2 : Z738

⚠ indicates safety critical components.

PARTS LIST

* New Parts

Parts without Parts No. are not supplied.

Les articles non mentionnes dans le Parts No. ne sont pas fournis.

Teile ohne Parts No. werden nicht geliefert.

ELECTRIC UNIT (X25-927X-XX)

Ref.No.	A d d	N e w	Parts No.	Description	Dest inati on
Q36-40			DTC143TUA	DIGITAL TRANSISTOR	E2
Q36-40			UN5216	DIGITAL TRANSISTOR	E2
Q36-42			DTC143TUA	DIGITAL TRANSISTOR	K1,M1,E1
Q36-42			UN5216	DIGITAL TRANSISTOR	K1,M1,E1
Q43			DTC124EUA	DIGITAL TRANSISTOR	
Q43			UN5212	DIGITAL TRANSISTOR	
Q44			CPH3105	TRANSISTOR	
Q45			DTC124EUA	DIGITAL TRANSISTOR	
Q45			UN5212	DIGITAL TRANSISTOR	
Q46			CPH3105	TRANSISTOR	
Q52			DTC143TUA	DIGITAL TRANSISTOR	
Q52			UN5216	DIGITAL TRANSISTOR	
Q101			DTA114YUA	DIGITAL TRANSISTOR	
Q101			UN5114	DIGITAL TRANSISTOR	
Q103			DTC124EUA	DIGITAL TRANSISTOR	K1,M1
Q103			UN5212	DIGITAL TRANSISTOR	K1,M1
Q111			2SB1277(Q,R)	TRANSISTOR	K1
Q112			DTC114YUA	DIGITAL TRANSISTOR	K1
Q112			UN5214	DIGITAL TRANSISTOR	K1
Q201			2SC4081	TRANSISTOR	E2
Q305			DTA114YUA	DIGITAL TRANSISTOR	K1
Q305			UN5114	DIGITAL TRANSISTOR	K1
Q305,306			DTA114YUA	DIGITAL TRANSISTOR	M1,E1,E2
Q305,306			UN5114	DIGITAL TRANSISTOR	M1,E1,E2
Q472			DTC144EUA	DIGITAL TRANSISTOR	K1,M1,E1
Q472			UN5213	DIGITAL TRANSISTOR	K1,M1,E1
Q473			2SC4081	TRANSISTOR	
Q474			2SA2057	TRANSISTOR	
Q475			2SC4081	TRANSISTOR	E2
Q476			2SA2057	TRANSISTOR	E2
Q703			2SA2057	TRANSISTOR	
Q704			2SC4081	TRANSISTOR	
TH1			PTH9C42BD471Q	POSITIVE RESISTOR	
FE1			X86-3530-11	TUNER UNIT	K1
FE1			X86-3532-70	TUNER UNIT	M1,E1,E2
DAUGHTER UNIT (X89-253X-XX)					
CN1			E40-9488-05	SOCKET FOR PIN ASSY (20P)	
J1			E58-0865-05	RECTANGULAR RECEPTACLE (16P)	
R1			RK73EB2E471J	CHIP R 470 J 1/4W	
R2			RK73EB2E241J	CHIP R 240 J 1/4W	
R3			RK73EB2E471J	CHIP R 470 J 1/4W	
R4-6			RK73EB2E241J	CHIP R 240 J 1/4W	
R7			RK73EB2E471J	CHIP R 470 J 1/4W	
R8			RK73EB2E511J	CHIP R 510 J 1/4W	
R9			RK73EB2E471J	CHIP R 470 J 1/4W	
R10			RK73EB2E221J	CHIP R 220 J 1/4W	M1,E1,E2
R11			RK73EB2E221J	CHIP R 220 J 1/4W	M1,E1,E2
S1			S70-0856-05	TACT SWITCH	M1,E1,E2
S1			S70-0873-05	TACT SWITCH	K1

Ref.No.	A d d	N e w	Parts No.	Description	Dest inati on

K1 : KDC-X959 M1 : KDC-Z939 E1 : Z838W E2 : Z738

⚠ indicates safety critical components.

SPECIFICATIONS

● KDC-X959 (K)

FM Section

Frequency Range	87.9MHz-107.9MHz
(Frequency Step)	(200kHz)
Channel Space Selection	50k/200kHz
Usable Sensitivity (S/N:30dB)	9.3dBf (0.8μV/75Ω)
Quieting Sensitivity (S/N:50dB)	15.2dBf (1.6μV/75Ω)
Frequency Response (±3.0dB)	30Hz-15kHz
S/N	70dB (MONO)
Selectivity	≥ 80dB (±400kHz)
Stereo Separation	40dB (1kHz)

AM Section

Frequency Range	530kHz-1700kHz
(Frequency Step)	(10kHz)
Channel Space Selection	9k/10kHz
Usable Sensitivity (S/N:20dB)	28dBμ (25μV)

CD Section

Laser Diode	GaAlAs (λ=780nm)
Digital Filter (D/A)	8 Times Over Sampling
D/A Converter	1 Bit
Spindle Speed	1000-400rpm (CLV • 2times)
Wow & Flutter	Below Measurable Limit
Frequency Response	10Hz-20kHz (±1dB)
Total Harmonic Distortion	0.01% (1kHz)
S/N Ratio	96dB (1kHz)
Dynamic Range	95dB
Channel Separation	90dB
MP3 Decode	Compliant with MPEG-1.0/2.0/2.5 AudioLayer-3
WMA Decode	Compliant with Windows Media Audio 8

AMPLIFIER Section

Preout Level/Load -Unbalansed	4500mV/10kΩ (CD/CD-CH)
Preout Impedance	≤ 80Ω
Maximum Power	50W×4
Full Bandwidth Power (at less then 1%THD)	22W×4

AUX Input

Frequency Response	20Hz-20kHz (±1dB)
Maximum Input Level	1.2V
Input Impedance	≥ 44kΩ

TONE Section

Bass	100Hz±10dB
Middle	1kHz±10dB
Treble	10kHz±10dB

General

Operating Voltage	14.4V (11V-16V allowable)
Current Consumption	10A
Installation Size (W)	180mm (7-1/16 in.)
(H)	50mm (1-15/16 in.)
(D)	159mm (6-1/4 in.)
Weight	1.4kg (3.08lbs.)

● KDC-Z939 (M)

FM Section

Frequency Range	87.5MHz-108.0MHz
(Frequency Step)	(50kHz)
Usable Sensitivity (S/N:26dB)	0.7μV/75Ω
Quieting Sensitivity (S/N:46dB)	1.6μV/75Ω
Frequency Response (±3.0dB)	30Hz-15kHz
S/N	65dB (MONO)
Selectivity (DIN)	≥ 80dB (±400kHz)
Stereo Separation	35dB (1kHz)

AM Section

Frequency Range	531kHz-1611kHz
(Frequency Step)	(9kHz)
Usable Sensitivity (S/N:20dB)	25μV

LW Section

Frequency Range	153kHz-281kHz
Usable Sensitivity (S/N:20dB)	45μV

CD Section

Laser Diode	GaAlAs (λ=780nm)
Digital Filter (D/A)	8 Times Over Sampling
D/A Converter	1 Bit
Spindle Speed	1000-400rpm (CLV • 2times)
Wow & Flutter	Below Measurable Limit
Frequency Response	10Hz-20kHz (±1dB)
Total Harmonic Distortion	0.01% (1kHz)
S/N Ratio	96dB (1kHz)
Dynamic Range	95dB
Channel Separation	90dB
MP3 Decode	Compliant with MPEG-1.0/2.0/2.5 AudioLayer-3
WMA Decode	Compliant with Windows Media Audio 8

AMPLIFIER Section

Preout Level/Load -Unbalansed	4500mV/10kΩ (CD/CD-CH)
Preout Impedance	≤ 80Ω
Maximum Power	50W×4
Full Bandwidth Power (at less then 1%THD)	22W×4

AUX Input

Frequency Response	20Hz-20kHz (±1dB)
Maximum Input Level	1.2V
Input Impedance	≥ 44kΩ

TONE Section

Bass	100Hz±10dB
Middle	1kHz±10dB
Treble	10kHz±10dB

General

Operating Voltage	14.4V (11V-16V allowable)
Current Consumption	10A
Installation Size (W)	180mm
(H)	50mm
(D)	159mm
Weight	1.4kg

KDC-X959/Z939,Z738,Z838W

SPECIFICATIONS

● Z738 (E)

FM Section

Frequency Range (Frequency Step)	87.5MHz-108.0MHz (50kHz)
Usable Sensitivity (S/N:26dB)	0.7 μ V/75 Ω
Quieting Sensitivity (S/N:46dB)	1.6 μ V/75 Ω
Frequency Response (\pm 3.0dB)	30Hz-15kHz
S/N	65dB (MONO)
Selectivity (DIN)	\geq 80dB (\pm 400kHz)
Stereo Separation	35dB (1kHz)

MW Section

Frequency Range (Frequency Step)	531kHz-1611kHz (9kHz)
Usable Sensitivity (S/N:20dB)	25 μ V

LW Section

Frequency Range	153kHz-281kHz
Usable Sensitivity (S/N:20dB)	45 μ V

CD Section

Laser Diode	GaAlAs (λ =780nm)
Digital Filter (D/A)	8 Times Over Sampling
D/A Converter	1 Bit
Spindle Speed	500-200rpm (CLV)
Wow & Flutter	Below Measurable Limit
Frequency Response	10Hz-20kHz (\pm 1dB)
Total Harmonic Distortion	0.01% (1kHz)
S/N Ratio	93dB (1kHz)
Dynamic Range	93dB
Channel Separation	85dB

AMPLIFIER Section

Preout Level/Load -Unbalansed	1800mV/10k Ω (CD/CD-CH)
Preout Impedance	\leq 600 Ω
Maximum Power	50W \times 4
Power (DIN45324, +B=14.4V)	30W \times 4

TONE Section

Bass	100Hz \pm 10dB
Middle	1kHz \pm 10dB
Treble	10kHz \pm 10dB

General

Operating Voltage (11V-16V allowable)	14.4V
Current Consumption	10A
Installation Size (W) x (H) x (D)	180mm x 50mm x 159mm
Weight	1.4kg

● X838W (E)

FM Section

Frequency Range (Frequency Step)	87.5MHz-108.0MHz (50kHz)
Usable Sensitivity (S/N:26dB)	0.7 μ V/75 Ω
Quieting Sensitivity (S/N:46dB)	1.6 μ V/75 Ω
Frequency Response (\pm 3.0dB)	30Hz-15kHz
S/N	65dB (MONO)
Selectivity (DIN)	\geq 80dB (\pm 400kHz)
Stereo Separation	35dB (1kHz)

MW Section

Frequency Range (Frequency Step)	531kHz-1611kHz (9kHz)
Usable Sensitivity (S/N:20dB)	25 μ V

LW Section

Frequency Range	153kHz-281kHz
Usable Sensitivity (S/N:20dB)	45 μ V

CD Section

Laser Diode	GaAlAs (λ =780nm)
Digital Filter (D/A)	8 Times Over Sampling
D/A Converter	1 Bit
Spindle Speed	1000-400rpm (CLV • 2times)
Wow & Flutter	Below Measurable Limit
Frequency Response	10Hz-20kHz (\pm 1dB)
Total Harmonic Distortion	0.01% (1kHz)
S/N Ratio	96dB (1kHz)
Dynamic Range	95dB
Channel Separation	90dB
MP3 Decode	Compliant with MPEG-1.0/2.0/2.5 AudioLayer-3
WMA Decode	Compliant with Windows Media Audio 8

AMPLIFIER Section

Preout Level/Load -Unbalansed ...	4500mV/10k Ω (CD/CD-CH)
Preout Impedance	\leq 80 Ω
Maximum Power	50W \times 4
Power (DIN45324, +B=14.4V)	30W \times 4

TONE Section

Bass	100Hz \pm 10dB
Middle	1kHz \pm 10dB
Treble	10kHz \pm 10dB

General

Operating Voltage (11V-16V allowable) ...	14.4V
Current Consumption	10A
Installation Size (W) x (H) x (D)	180mm x 50mm x 159mm
Weight	1.4kg

KENWOOD follows a policy of continuous advancements in development. For this reason specifications may be changed without notice.

KENWOOD CORPORATION

14-6, Dogenzaka 1-chome, Shibuya-ku, Tokyo 150-8501, Japan

KENWOOD SERVICE CORPORATION

P.O. Box 22745, 2201 East Dominguez Street,
Long Beach, CA90801-5745, U.S.A.

KENWOOD ELECTRONICS CANADA INC.

6070 Kestrel Road, Mississauga, Ontario, Canada L5T 1S8

KENWOOD ELECTRONICS LATIN AMERICA S.A.

P.O. Box 55-2791 Paitilla, Plaza Credicorp Bank Panama,
Piso 9, Oficina 901, Calle 50, Panama, Republic of Panama

KENWOOD ELECTRONICS BRASIL LTDA.

Alameda Ministro Rocha Azevedo No. 456,
Edifício Jau, 10o Andar, Cerqueira César, Cep 0140-001,
São Paulo-SP-Brasil

KENWOOD ELECTRONICS UK LIMITED

Kenwood House, Dwright Road, Watford, Herts,
WD1 8EB, United Kingdom

KENWOOD ELECTRONICS DEUTSCHLAND GMBH

Rembrücker-Str. 15, 63150 Heusenstamm, Germany

KENWOOD ELECTRONICS FRANCE S.A.

13, Boulevard Ney, 75018 Paris, France

KENWOOD ELECTRONICS BELGIUM N.V.

Leuvensesteenweg 248 J, 1800 Vilvoorde, Belgium

KENWOOD ELECTRONICS ITALIA S.p.A.

Via G. Sirtori 7/9, 20129 Milano, Italy

KENWOOD IBÉRICA S.A.

Bolivia, 239-08020 Barcelona, Spain

KENWOOD ELECTRONICS AUSTRALIA PTY. LTD.

(A.C.N. 001 499 074)
16 Giffnock Avenue, Centrecourt Estate, North Ryde,
N.S.W. 2113, Australia

KENWOOD ELECTRONICS (HONG KONG) LTD.

Unit 3712-3724, Level 37, Tower 1, Metroplaza,
223 Hing Fong Road, Kwai Fong, N.T., Hong Kong

KENWOOD ELECTRONICS GULF FZE

P.O. Box 61318, Jebel Ali, Dubai, U.A.E.

KENWOOD ELECTRONICS (THAILAND) CO., LTD.

2019 New Pechburi Road, Bangkapi, Huaykwang,
Bangkok, 10320 Thailand

KENWOOD ELECTRONICS SINGAPORE PTE. LTD.

1 Genting Lane, #07-00, Kenwood Building, Singapore 349544

KENWOOD ELECTRONICS (MALAYSIA) SDN BHD

#4.01 Level 4, Wisma Academy Lot 4A, Jalan 19/1,
46300 Petaling Jaya, Selangor Darul Ehsan, Malaysia